

IEEE Application Guide for Transient Recovery Voltage for AC High-Voltage Circuit Breakers Rated on a Symmetrical Current Basis

Sponsor
**Switchgear Committee
of the
IEEE Power Engineering Society**

Approved September 22, 1994
IEEE Standards Board

Abstract: Procedures and calculations necessary to apply the standard transient recovery voltage (TRV) ratings for ac high-voltage circuit breakers rated above 1000 V and on a symmetrical current basis are covered. The capability limits of these circuit interrupting devices are determined largely by the TRV. TRV ratings are compared with typical system TRV duties.

Keywords: high-voltage circuit breakers, transient recovery voltage

The Institute of Electrical and Electronics Engineers Inc.
345 East 47th Street, New York, NY 10017-2394, USA
Copyright © 1995 by the Institute of Electrical and Electronics Engineers, Inc.
All rights reserved. Published in the United States of America.
ISBN 1-55937-467-5

No part of this publication may be reproduced in any form, in an electronic retrieval system or otherwise, without the prior written permission of the publisher.

IEEE Standards documents are developed within the Technical Committees of the IEEE Societies and the Standards Coordinating Committees of the IEEE Standards Board. Members of the committees serve voluntarily and without compensation. They are not necessarily members of the Institute. The standards developed within IEEE represent a consensus of the broad expertise on the subject within the Institute as well as those activities outside of IEEE that have expressed an interest in participating in the development of the standard.

Use of an IEEE Standard is wholly voluntary. The existence of an IEEE Standard does not imply that there are no other ways to produce, test, measure, purchase, market, or provide other goods and services related to the scope of the IEEE Standard. Furthermore, the viewpoint expressed at the time a standard is approved and issued is subject to change brought about through developments in the state of the art and comments received from users of the standard. Every IEEE Standard is subjected to review at least every five years for revision or reaffirmation. When a document is more than five years old and has not been reaffirmed, it is reasonable to conclude that its contents, although still of some value, do not wholly reflect the present state of the art. Users are cautioned to check to determine that they have the latest edition of any IEEE Standard.

Comments for revision of IEEE Standards are welcome from any interested party, regardless of membership affiliation with IEEE. Suggestions for changes in documents should be in the form of a proposed change of text, together with appropriate supporting comments.

Interpretations: Occasionally questions may arise regarding the meaning of portions of standards as they relate to specific applications. When the need for interpretations is brought to the attention of IEEE, the Institute will initiate action to prepare appropriate responses. Since IEEE Standards represent a consensus of all concerned interests, it is important to ensure that any interpretation has also received the concurrence of a balance of interests. For this reason IEEE and the members of its technical committees are not able to provide an instant response to interpretation requests except in those cases where the matter has previously received formal consideration.

Comments on standards and requests for interpretations should be addressed to:

Secretary, IEEE Standards Board
445 Hoes Lane
P.O. Box 1331
Piscataway, NJ 08855-1331
USA

IEEE Standards documents may involve the use of patented technology. Their approval by the Institute of Electrical and Electronics Engineers does not mean that using such technology for the purpose of conforming to such standards is authorized by the patent owner. It is the obligation of the user of such technology to obtain all necessary permissions.

Introduction

(This introduction is not part of IEEE Std C37.011-1994, IEEE Application Guide for Transient Recovery Voltage for AC High-Voltage Circuit Breakers Rated on a Symmetrical Current Basis.)

The manner of presentation of TRV applications has been changed in this revision of IEEE Std C37.011-1979 from an emphasis on system application examples to a dual emphasis on 1) a generalized description of the effect of circuit parameters on TRV shape, rate of rise, and magnitude, and 2) a relating of the TRV requirements as presented in the standards IEEE Std C37.04-1979, ANSI C37.06-1987, and IEEE Std C37.09-1979 to these various circuit conditions. The methods for determining a circuit breaker's TRV withstand capability from circuit breaker standard ratings are also illustrated.

Examples of techniques for calculating TRVs for different circuit conditions are presented in the annexes. The annexes also include an updated and expanded listing of typical capacitance values of substation components, graphs of transformer limited fault frequencies, and an updated bibliography.

At the time this document was published, it was under consideration for approval as an American National Standard. The Accredited Standards Committee on Power Switchgear, C37, had the following members at the time this document was sent to letter ballot:

E. Byron, , *Chair*
M. Williams, *Secretary*
M. Calwise, *Program Administrator*
A. K. McCabe, *Executive Vice-Chair of High-Voltage Switchgear Standards*
(vacant), *Executive Vice-Chair of Low-Voltage Switchgear Standards*
D. L. Swindler, *Executive Vice-Chair of IEC Activities*

<i>Organization Represented</i>	<i>Name of Representative</i>
Association of Iron and Steel Engineers	(vacant)
Electric Light and Power Group	M. C. Mingoia D. J. Borchart T. E. Bruck J. H. Provanzana J. D. Stewart G. R. Brandenberger (<i>Alt.</i>) A. K. McCabe (<i>Alt.</i>)
Institute of Electrical and Electronics Engineers	D. F. Peelo L. B. Beard H. L. Bowles P. W. Dwyer D. Signon S. C. Atkinson (<i>Alt.</i>) D. G. Kumbara (<i>Alt.</i>) L. V. McCall (<i>Alt.</i>)
Laubach Associates	W. Laubach

Organization Represented

Name of Representative

National Electrical Manufacturers Association

R. Garzon

G. Haynes

W. Kracht

H. L. Miller

T. Olson

E. Byron (*Alt.*)

G. T. Jones (*Alt.*)

G. Sakats (*Alt.*)

S. Stone (*Alt.*)

D. L. Swindler (*Alt.*)

Tennessee Valley Authority

D. N. Reynolds

Testing Laboratory Group

L. Frier

U.S. Department of the Army, Office of the Chief of Engineers

J. A. Gilson

U.S. Department of the Interior, Bureau of Reclamation

R. Arnold

U.S. Department of the Navy, Naval Construction Battalion center

R. L. Clark

Western Area Power Administration

G. D. Birney

The following is a list of participants in the IEEE Working Group on Transient Recovery Voltage:

T. J. Tobin, Chair

H. W. Anderl

H. L. Hess

W. E. Reid

J. A. Bonner

S. R. Lambert

J. R. Rostron

L. E. Brothers

A. K. McCabe

E. M. Ruoss

J. H. Brunke

B. Patel

J. H. Simpson

R. D. Garzon

D. F. Peelo

H. M. Smith

W. E. Harper

J. C. Reckleff

R. K. Smith

The following persons were on the balloting committee:

C. S. Alexander

A. Dixon

W. F. Hoenigmann

R. J. Alton

G. W. Dolloff

N. V. Holmgren

J. G. Angelis

J. J. Dravis

P. L. Kolarik

R. H. Arndt

C. J. Dvorak

D. G. Kumbera

S. C. Atkinson

P. W. Dwyer

S. R. Lambert

L. R. Beard

R. D. Garzon

D. M. Larson

H. L. Bowles

L. W. Gaussa

W. E. Laubach

M. T. Brown

G. Genest

J. G. Leach

J. H. Brunke

K. I. Gray

G. N. Lester

C. G. Burland

W. E. Harper

D. L. Lott

R. L. Capra

K. D. Hendrix

E. L. Luehring

L. V. Chabala

H. L. Hess

J. A. Maneatis

R. Matulic
P. C. Mayo
A. K. McCabe
L. V. McCall
R. A. McMaster
H. W. Mikulecky
D. C. Mills
G. F. Montillet
F. J. Muench
A. F. Parks

D. F. Peelo
G. O. Perkins
R. Ranjan
J. E. Reed
A. B. Rishworth
H. C. Ross
L. R. Saavedra
L. H. Schmidt
E. W. Schmunk
C. A. Schwalbe

J. C. Scott
G. St. Jean
D. L. Swindler
S. H. Telander
F. C. Teufel
E. F. Veverka
C. L. Wagner
W. R. Wilson
B. F. Wirtz

When the IEEE Standards Board approved this standard on September 22, 1994, it had the following membership:

Wallace S. Read, *Chair*
Donald C. Loughry, *Vice Chair*
Andrew G. Salem, *Secretary*

Gilles A. Baril
Bruce B. Barrow
José A. Berrios de la Paz
Clyde R. Camp
James Costantino
Stephen L. Diamond
Donald C. Fleckenstein
Jay Forster*
Ramiro Garcia

Donald N. Heirman
Richard J. Holleman
Jim Isaak
Ben C. Johnson
Sonny Kasturi
Lorraine C. Kevra
E. G. "Al" Kiener
Ivor N. Knight
Joseph L. Koepfinger*

D. N. "Jim" Logothetis
L. Bruce McClung
Marco W. Migliaro
Mary Lou Padgett
Arthur K. Reilly
Ronald H. Reimer
Gary S. Robinson
Leonard L. Tripp

*Member Emeritus

Also included are the following nonvoting IEEE Standards Board liaisons:

Satish K. Aggarwal
James Beall

Richard B. Engelman
Robert E. Hebner

David E. Soffrin

Rochelle Stern
IEEE Standards Project Editor

CLAUSE	PAGE
1. Overview	1
1.1 Scope	1
1.2 Purpose	1
2. References	1
3. Transient recovery voltage (TRV)	2
3.1 General	2
3.2 Effect of circuit breaker on transient recovery voltage	2
3.3 Method of rating and application	3
4. Application considerations	3
4.1 General	3
4.2 Circuit breaker capability	4
4.3 Exponential (damped) TRV	11
4.4 Oscillatory (underdamped) TRV	14
4.5 Applications where breaker capability is exceeded	17
Annex A (Informative) TRV calculation techniques	18
Annex B (Informative) Typical capacitance values for various equipment	35
Annex C (Informative) Bibliography	41

IEEE Application Guide for Transient Recovery Voltage for AC High-Voltage Circuit Breakers Rated on a Symmetrical Current Basis

1. Overview

1.1 Scope

This application guide covers procedures and calculations necessary to apply the standard transient recovery voltage (TRV) ratings for ac high-voltage circuit breakers rated above 1000 V and on a symmetrical current basis. The capability limits of these circuit interrupting devices are determined largely by the TRV. This application guide is not included in other existing circuit breaker standards. In this document, the TRV ratings are compared with typical system TRV duties. An example TRV calculation is given in annex A.

1.2 Purpose

The purpose of this standard is to provide an application guide on the TRV ratings given in IEEE Std C37.04-1979¹ for ac high-voltage circuit breakers rated on a symmetrical current basis. Definitions, rating structure, test procedures, and preferred transient voltage ratings and related required capabilities are included in IEEE Std C37.04-1979, ANSI C37.06-1987, and IEEE Std C37.09-1979. IEEE Std C37.010-1979, IEEE Std C37.010b-1985, and IEEE Std C37.010e-1985 apply in other respects to these circuit breakers.

2. References

This guide shall be used in conjunction with the following publications.

ANSI C37.06-1987, AC High-Voltage Circuit Breakers Rated on a Symmetrical Current Basis—Preferred Ratings and Related Required Capabilities.²

¹Information on references can be found in clause 2.

²ANSI publications are available from the Sales Department, American National Standards Institute, 11 West 42nd Street, 13th Floor, New York, NY 10036, USA.

ANSI C37.06a-1989, AC High-Voltage Circuit Breakers Rated on a Symmetrical Current Basis—Preferred Ratings and Related Required Capabilities.

IEEE Std C37.04-1979, IEEE Standard Rating Structure for AC High-Voltage Circuit Breakers Rated on a Symmetrical Current Basis (ANSI).³

IEEE Std C37.09-1979, IEEE Standard Test Procedure for AC High-Voltage Circuit Breakers Rated on a Symmetrical Current Basis (ANSI).

IEEE Std C37.010-1979 (Reaff 1988), IEEE Application Guide for AC High-Voltage Circuit Breakers Rated on a Symmetrical Current Basis (ANSI).

IEEE Std C37.010b-1985 (Reaff 1988), Supplement to IEEE Std C37.010-1979 (ANSI).

IEEE Std C37.010e-1985 (Reaff 1988), Supplement to IEEE Std C37.010-1979 (ANSI).

3. Transient recovery voltage (TRV)

3.1 General

During the interruption process the arc voltage, which occurs across the terminals of a pole of a circuit breaker prior to current zero, approaches the normal-frequency pole-unit recovery voltage occurring after current zero, in a manner called the transient recovery voltage (TRV). If the circuit breaker is able to withstand the TRV, and also the normal-frequency pole-unit recovery voltage, circuit interruption will be successful.

TRVs can be oscillatory, triangular, or exponential and can occur as a combination of these forms. The most severe oscillatory or exponential recovery voltages tend to occur across the first pole to open of a circuit breaker interrupting a three-phase ungrounded symmetrical fault at its terminal when the system voltage is maximum. The triangular recovery voltages are associated with line faults. The initial rate of rise of the recovery voltages for line faults becomes greater the closer the fault is to the circuit breaker; however, the magnitude of this line side triangular wave decreases as the rate of rise increases. Generally, the source recovery voltage is much slower and only the triangular recovery voltage is effective in the early time of the TRV. The amplitude of the recovery voltages for these line faults is determined on a single-phase basis during their early portions.

3.2 Effect of circuit breaker on transient recovery voltage

The circuit TRV can be modified or changed by the circuit breaker's design or by the circuit breaker's action. Therefore, the transient recovery voltage measured across the terminals of two different types of circuit breakers under identical conditions can be different. Recognizing the modifying abilities of each of the various circuit breakers would be an immense task, when either calculating a TRV or when specifying a related value for the circuit breaker.

To simplify both rating and application, the power system electrical characteristics are defined or calculated ignoring the effect of the circuit breaker. Thus, the TRV, which results when an ideal circuit breaker interrupts, is used as the reference for both rating and application. This TRV is called the inherent TRV. An ideal circuit breaker has no modifying effects on the electrical characteristics of a system and, when conducting, its terminal impedance is zero; at current zero its terminal impedance changes from zero to infinity.

³IEEE publications are available from the Institute of Electrical and Electronics Engineers, 445 Hoes Lane, P.O. Box 1331, Piscataway, NJ 08855-1331, USA.

3.3 Method of rating and application

3.3.1 Selection of a circuit breaker

The TRV ratings for circuit breakers are applicable for interrupting three-phase ungrounded terminal faults at the rated symmetrical short circuit current and at the maximum rated voltage of the circuit breaker. For values of fault current other than rated and for line faults, related TRV capabilities are given. Rated and related TRV capabilities are described in 5.11 of IEEE Std C37.04-1979 and given in detail in ANSI C37.06-1979.

The TRV ratings define a withstand boundary. A circuit TRV that exceeds this boundary at rated short circuit current, or the modified boundary for currents other than rated, is in excess of the circuit breaker's rated or related capability. Either a different circuit breaker should be used, or the system should be modified in such a manner as to change its transient recovery voltage characteristics. The addition of capacitors to a bus or line is one method that can be used to improve the system's recovery voltage characteristics.

3.3.2 Effect of asymmetry on transient recovery voltage

The TRVs that occur when interrupting asymmetrical current values are generally less severe than when interrupting the related symmetrical current. Circuit breakers have the capability of interrupting these asymmetrical currents providing the circuit breakers are applied within their rating.

4. Application considerations

4.1 General

The system TRV characteristic is often complex, and a computer simulation may be necessary for evaluation. In many cases, however, the predominant TRV characteristic may be represented by an exponential, oscillatory, or triangular response as shown in figures 1, 2, and 3, respectively.

A typical exponential TRV is shown in figure 1. This exponential TRV typically occurs when at least one transformer and one line are on the unfaulted side of the circuit breaker when a three-phase ungrounded fault is cleared at the breaker terminals.

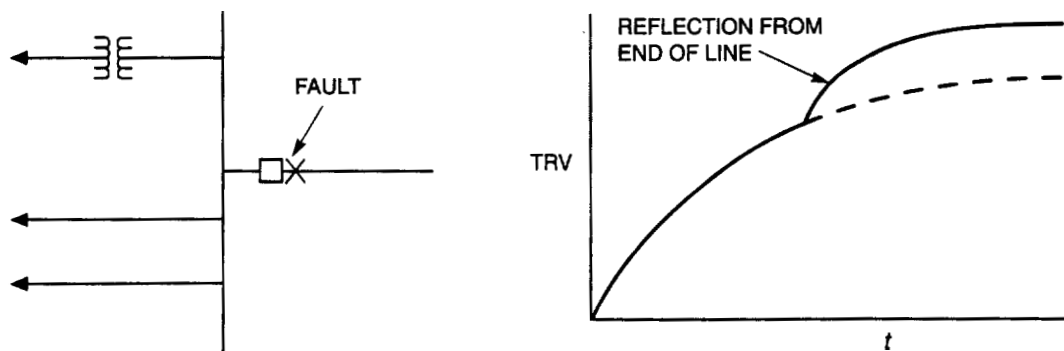

Figure 1—Exponential TRV characteristic

The oscillatory TRV shown in figure 2 occurs when a fault is limited by a transformer or a series reactor and no transmission line or cable surge impedance is present to provide damping.

Short-line faults (SLF) exhibit the characteristic shown in figure 3. The transmission line surge impedance, Z , determines the nature of the TRV. The rate-of-rise of the saw-tooth shaped TRV is generally higher than that experienced with exponential or oscillatory TRVs.

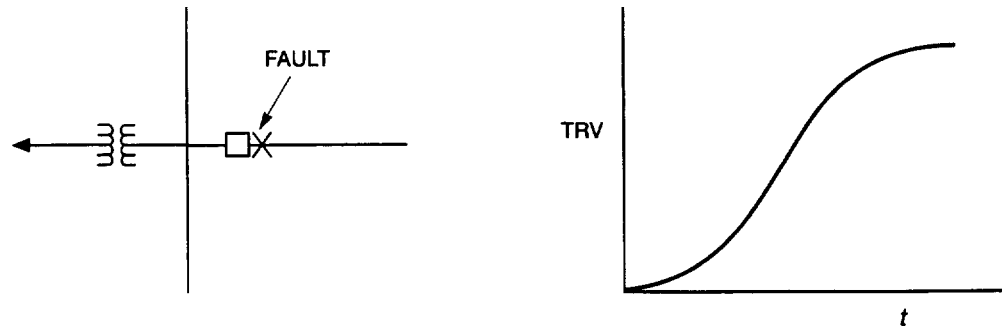

Figure 2—Oscillatory TRV characteristic

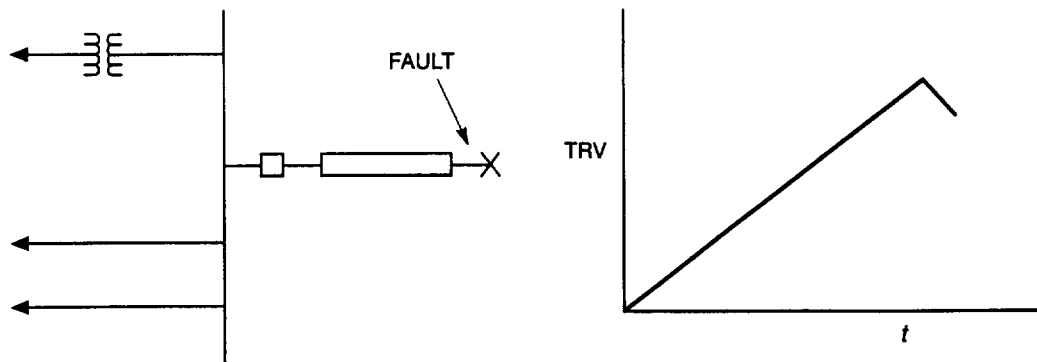

Figure 3—Short-line fault TRV characteristic

The three-phase ungrounded fault is usually the most severe terminal fault type and is used as the basis of rating. Short line faults generally have higher rates-of-rise of recovery voltage than do terminal fault TRVs, but have lower crest voltage magnitudes.

Examples given in this clause illustrate the use of the standard for some typical system applications. System TRVs may be complex and are often calculated using digital or analog computers. Consequently, the details of the calculations for the examples in this section are not included. An example of a detailed TRV calculation is given in annex A. In addition, typical equipment capacitance values are given in annex B.

4.2 Circuit breaker capability

Rated and related circuit breaker transient recovery voltage capabilities are defined by parameters given in ANSI C37.06-1987. For breakers rated 121 kV and above, the parameters describe an exponential-cosine TRV envelope for three-phase ungrounded terminal faults where the symmetrical short circuit currents are above 30% of the breaker's capability. At 30% and below, the TRV is described by a 1-cosine envelope. For breakers rated 72.5 kV and below, the envelope is described by a 1-cosine envelope over the entire current range. Short line fault capability, which is a related capability, is described and defined in IEEE Std C37.04-1979.

4.2.1 Three-phase ungrounded terminal fault

As an example, figure 4 shows the three-phase ungrounded fault related transient recovery voltage capability for a 550 kV circuit breaker at 75% of its symmetrical current rating.

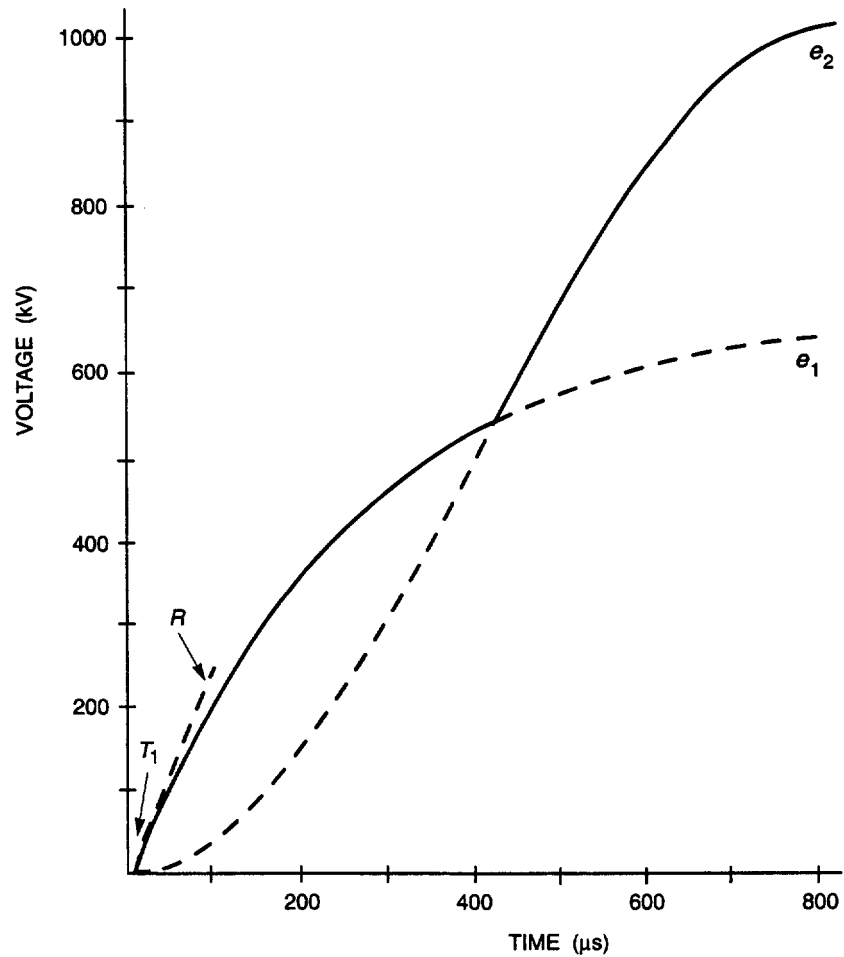

Figure 4—TRV related capability envelope for 550 kV circuit breaker at 75% of its rated fault current capability

The exponential-cosine envelope is defined by the larger of e_1 and e_2 in the following:

$$e_1 = E_1(1 - \varepsilon^{-t/T}) \text{ kV} \quad (1)$$

with a delay of T_1 μs

where

$$T = E_1/R$$

$$e_2 = \frac{E_2}{2}(1 - \cos(\pi t/T_2)) \text{ kV} \quad (2)$$

The constants in these equations (1) and (2) for this example are given in table 3 of ANSI C37.06-1987.

The multipliers to adjust for a fault current less than rated are given in table 6 of ANSI C37.06-1987. These multipliers are also given here in table 1.

NOTE — Rating values from ANSI C37.06-1979 are used in this guide for examples. While revisions to ANSI C37.06-1979 may occur in the future, the same fundamental applications apply.

Table 1—Related required transient recovery voltage capabilities of circuit breakers at various interrupting levels for terminal faults

Percent of interrupting rating*	Multipliers for rated parameters				
	72.5 kV and below		121 kV and above		
	E_2	T_2	R	E_2	T_2
100	1.00	1	1	1.00	1
60	1.07	0.67	2	1.07	0.5
30	1.13	0.4	0	1.13	0.2
7	1.17	0.4	0	1.17	0.2

NOTE — Interpolation between the above given points is linear, as shown in figure 5.

*Ratio of the symmetrical current component of the current being considered to the related required symmetrical interrupting capability (defined in 5.10.2.1 of IEEE Std C37.04-1979) is stated in percent.

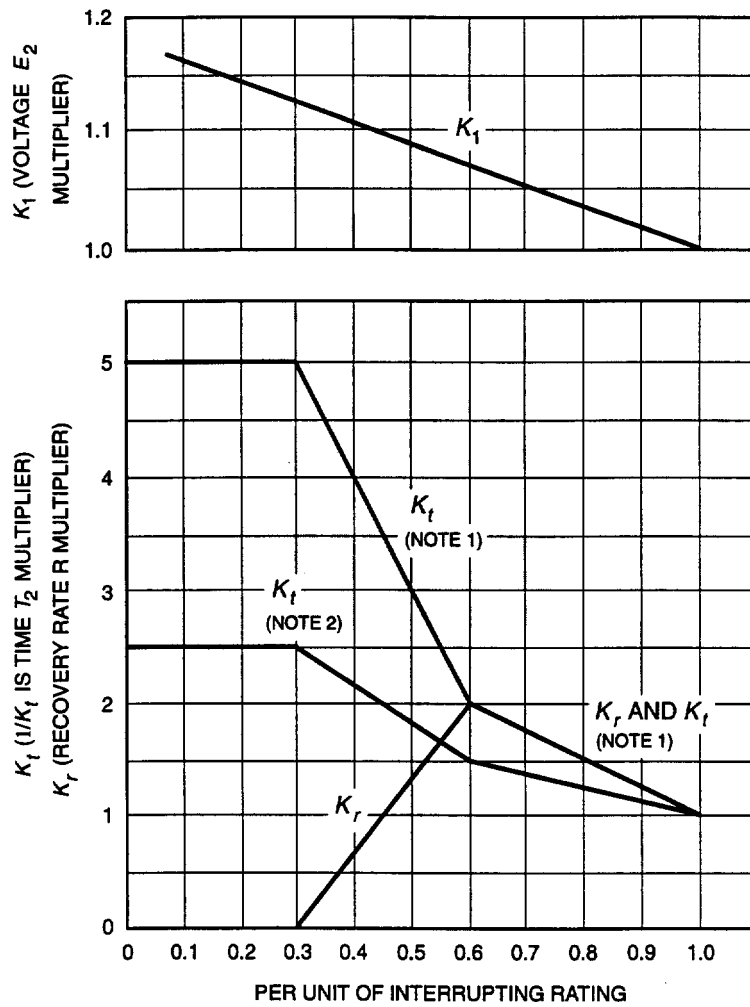

NOTES:

- 1 — $K_t = 121$ kV and above.
- 2 — $K_t = 72.5$ kV and below.
- 3 — See table 1.

Figure 5—TRV rate and voltage multipliers for fractions of rated current

The values for this example are summarized in the following:

From table 3 in ANSI C37.06-1987, for rated current and rated maximum voltage (E_{max}) = 550 kV:

$$E_1 = 1.5(\sqrt{2}/\sqrt{3})E_{max} = 674 \text{ kV}$$

$$E_2 = 1.76E_{max} = 968 \text{ kV}$$

$$R = 1.6 \text{ kV}/\mu\text{s}$$

$$T_2 = 1325\mu\text{s}$$

$$T_1 = 5.4\mu\text{s, time delay before exponential wave starts}$$

From table 6 in ANSI C37.06-1987, for 75% current:

$$K_r = 1.625$$

$$K_1 = 1.044$$

$$K_t = 1.625$$

where

K_r	is the rate R multiplying factor
K_1	is the voltage E_2 multiplying factor
K_t	is the time T_2 multiplying factor

TRV capability for 75% current:

$$\begin{aligned} E_1 &= 674 \text{ kV} \\ E_2 &= 968 \cdot 1.044 = 1011 \text{ kV} \\ R &= 1.6 \cdot 1.625 = 2.60 \text{ kV}/\mu\text{s} \\ T_2 &= 1325.0/1.625 = 815.4 \mu\text{s} \\ T_1 &= 5.4 \mu\text{s} \\ T &= E_1/R = 673.6/2.60 = 259.1 \mu\text{s} \end{aligned}$$

Based upon the evaluation of many actual system configurations, standards assume for 121 kV systems and above, that clearing terminal fault currents between 30% and 100% of rating will result in a TRV characteristic, which has an exponential-cosine waveform (see figure 1). For terminal fault currents between 7% and 30% for 121 kV systems and above, and for all terminal fault currents for 72.5 kV systems and below, the standards assume a 1-cosine waveform that is characteristic of a transformer limited fault illustrated in figure 2. The shapes of the TRV capability curves are adjusted by the factors given in figure 5 as is illustrated in figure 4. The general characteristics of the TRV envelopes defined by IEEE Std C37.04-1979 are illustrated in figures 6 and 7 as a function of the fault current magnitude.

4.2.2 Short-line fault

Short-line fault (SLF) capability is defined in 5.11.4.2 of IEEE Std C37.04-1979. Exhibiting a triangular waveshape with a relatively high rate-of-rise but a low peak magnitude compared to the three-phase ungrounded terminal fault, a typical SLF waveform is illustrated in figure 8.

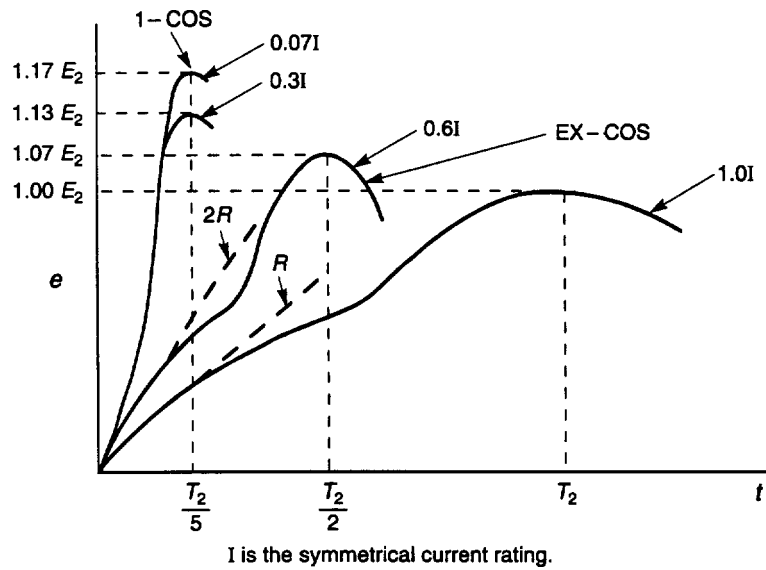

Figure 6—TRV envelopes, 121 kV and above

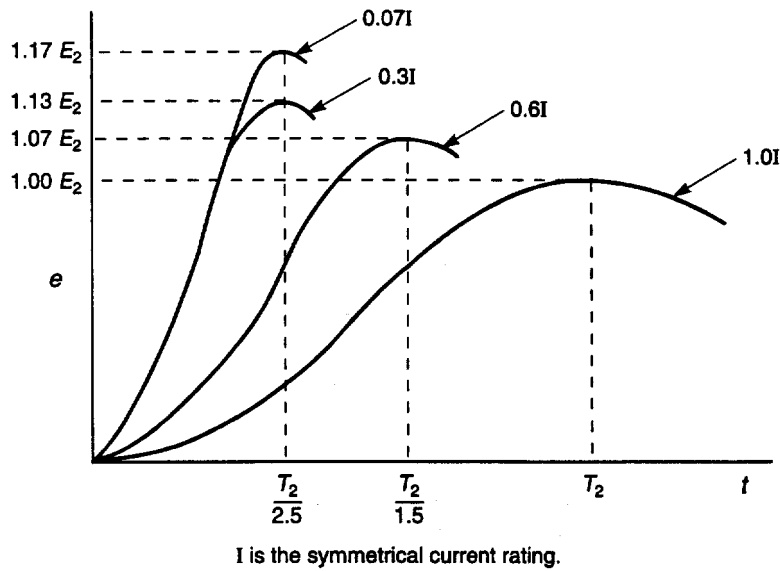

Figure 7—TRV envelopes, 72.5 kV and below

In general, it is not necessary to calculate the SLF TRV as long as the three-phase ungrounded bus or terminal fault TRVs are within rating and transmission line parameters are within the values specified in IEEE Std C37.04-1979. The transmission line parameters are given in terms of the effective surge impedance, Z , of the faulted line and the amplitude constant, d , defined as

$$d = \frac{6\omega Z\tau}{2X_{L1} + X_{L0}} \tag{3}$$

where

- Z is the effective surge impedance of the faulted line
 τ is the surge travel time per unit length (approximately 5.35 $\mu\text{s}/\text{mi}$ for overhead conductors)
 XL_1 & XL_0 are the fundamental frequency positive and zero sequence impedances per unit length of the faulted line
 ω is $2 \cdot \pi \cdot$ system power frequency (377 rad/s for a 60 Hz system)

The maximum values for Z and d as defined in IEEE Std C37.04-1979 are as follows:

242 kV and below:

$$Z = 450 \Omega$$

$$d = 1.8$$

362 kV and above:

$$Z = 360 \Omega$$

$$d = 1.6$$

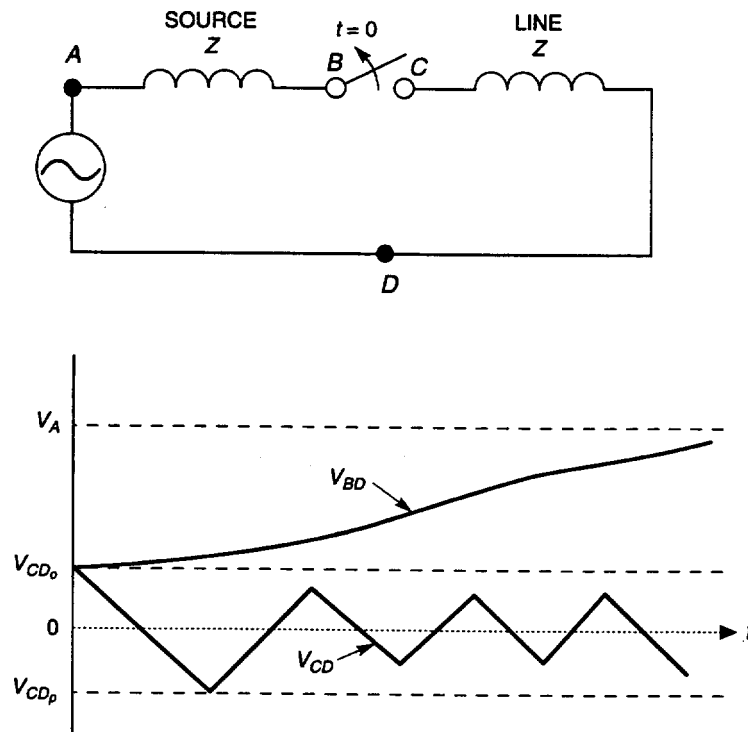

Figure 8—TRV wavelshape for short-line fault

4.2.3 Special fault conditions

Referring to figure 4, for fault currents less than rated, the prospective system TRV envelope may exceed the maximum envelope defined by the standards only at the very beginning of the waveform. In actuality, the standard defines a higher withstand in this region through the SLF capability. It is often unnecessary, but when it is needed, the user can apply the capability associated with SLFs to bus faults. The SLF capability is defined as a triangular wave in IEEE Std C37.09-1979 as follows:

$$e = d(1 - M) \sqrt{2} \left(\frac{1}{\sqrt{3}} E_{\max} \right) \text{ kV} \quad (4)$$

$$R_L = \sqrt{2} \omega \text{ MIZ} \times 10^{-6} \text{ kV}/\mu\text{s} \quad (5)$$

$$T_L = \frac{e}{R_L} \mu\text{s} \quad (6)$$

where

e	is the peak value (kV)
R_L	is the rate-of-rise (kV/ μs)
T_L	is the time to peak (μs)
d	is the amplitude constant given in 4.2.2
M	is the ratio of the fault current to the rated short circuit current
E_{max}	is the rated maximum voltage (kV)
I	is rated short circuit current (kA)
Z	is the surge impedance defined in IEEE Std C37.04-1979 (Ω)

In figure 9, the TRV capability curve for the example in 4.2.1 is shown with the short-line fault capability superimposed. For this example,

$$\begin{aligned} E_{\text{max}} &= 550 \text{ kV} \\ I &= 40 \text{ kA} \\ M &= 0.75 \\ \omega &= 377 \text{ rad/s} \end{aligned}$$

From IEEE Std C37.04-1979:

$$\begin{aligned} d &= 1.6 \\ Z &= 360 \omega \end{aligned}$$

Calculated:

$$\begin{aligned} e &= 180 \text{ kV} \\ R_L &= 5.76 \text{ kV}/\mu\text{s} \\ T_L &= 31.2 \mu\text{s} \end{aligned}$$

4.3 Exponential (damped) TRV

Figure 10 shows the one line diagram of a 500 kV substation. Figure 11 illustrates the TRV seen by circuit breaker A when clearing the three-phase ungrounded fault shown in figure 10 (circuit breaker B is open). This waveform is overdamped and exhibits an exponential waveshape. A reflection occurs from the end of the shortest line after approximately 535 μs , causing a slight increase in the TRV crest. The TRV capability curve (figure 4) is also shown in figure 11, indicating that the breaker TRV capability exceeds system requirements.

In some cases it may be necessary to use a higher current rated circuit breaker to obtain the desired TRV capability curve. In figure 12, the TRV capability curves for a 242 kV, 40 kA, and 63 kA circuit breaker are compared to a 30 kA fault application. It is evident that the 63 kA circuit breaker provides additional capability.

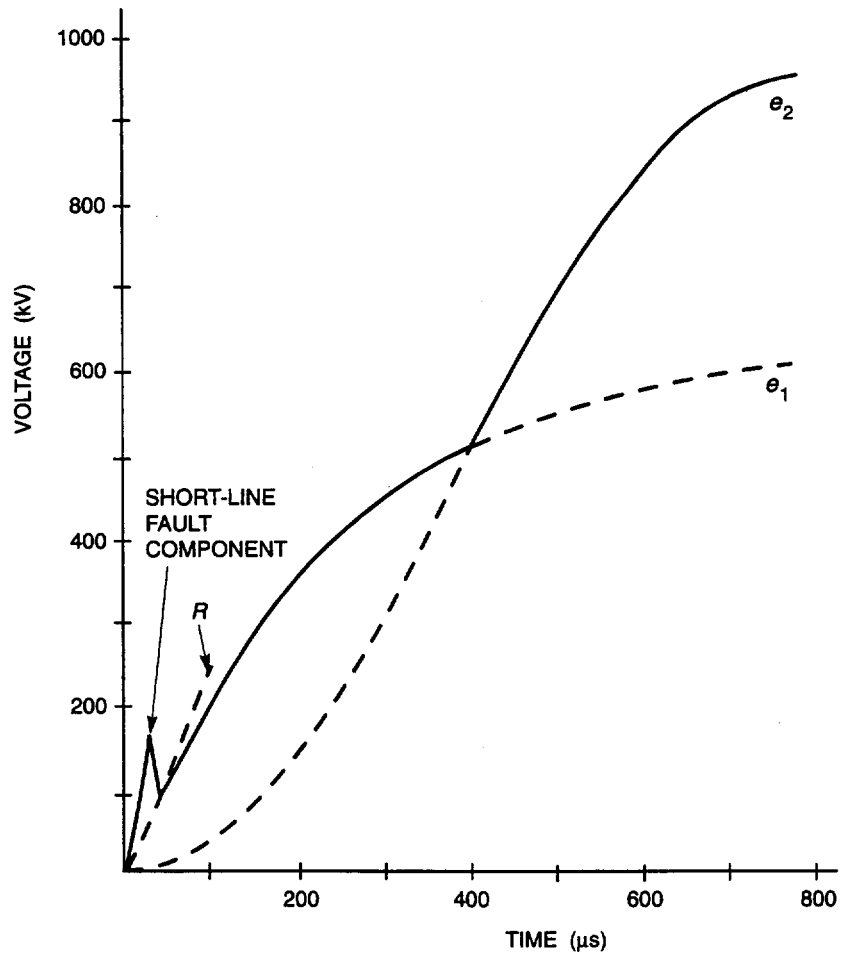

Figure 9—TRV related capability envelope for 550 kV circuit breaker at 75% of its rated fault current capability with SLF component

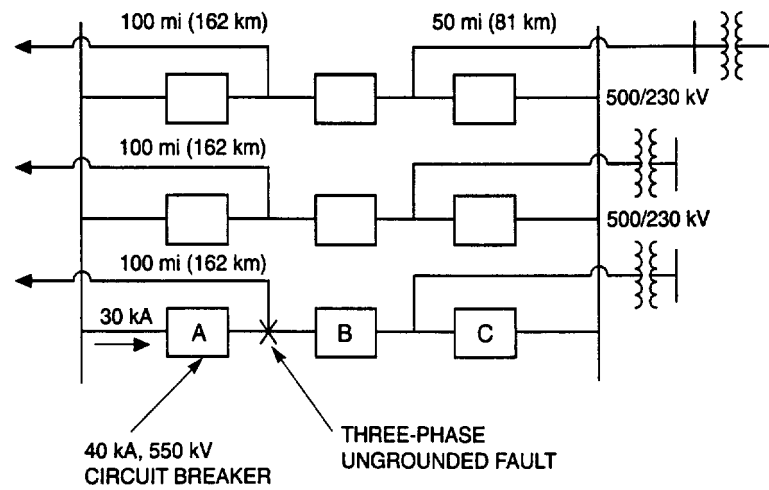

Figure 10—System configuration

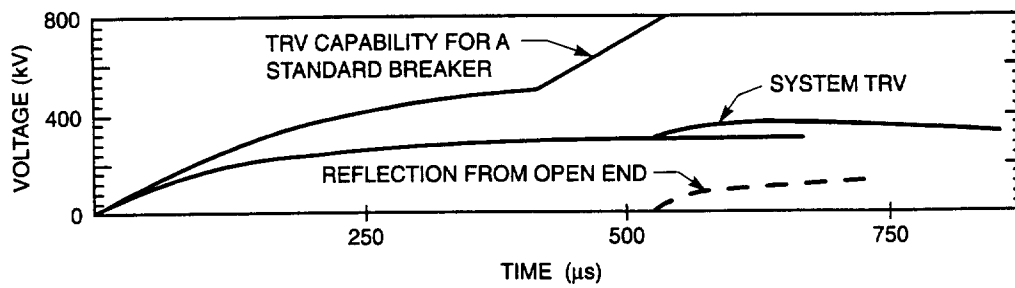

Figure 11—Three-phase ungrounded fault TRV

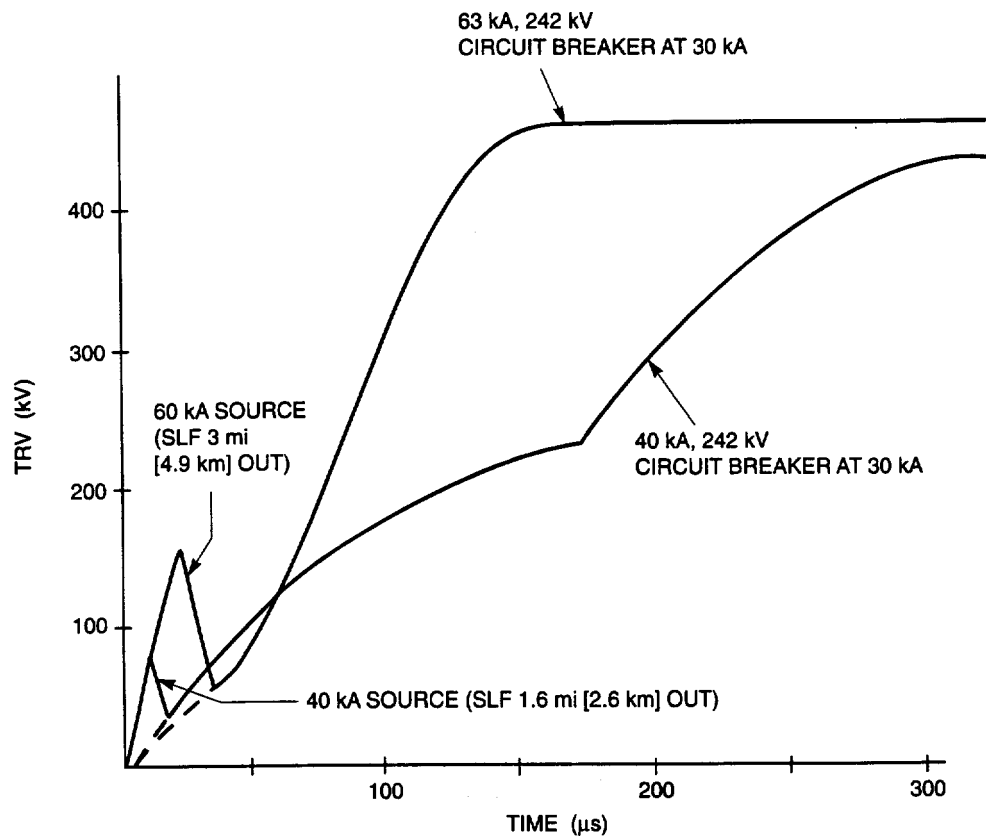

Figure 12—TRV capability curve for 40 kA and 63 kA circuit breakers

4.4 Oscillatory (underdamped) TRV

4.4.1 Transformer limited fault

In figure 13 the 40 kA, 145 kV circuit breaker has to clear a three-phase ungrounded fault at 10% of its rating. The resultant TRV is shown in figure 14. This TRV is determined by the inductance and capacitance of the transformer and the capacitance between the transformer and the circuit breaker. It is a high frequency transient that exceeds the capability curve defined by the standards.

Figure 15 illustrates the TRV for the same condition, but with additional capacitance assumed between the transformer and the circuit breaker. In this case, the system TRV curve is within the standard capability envelope.

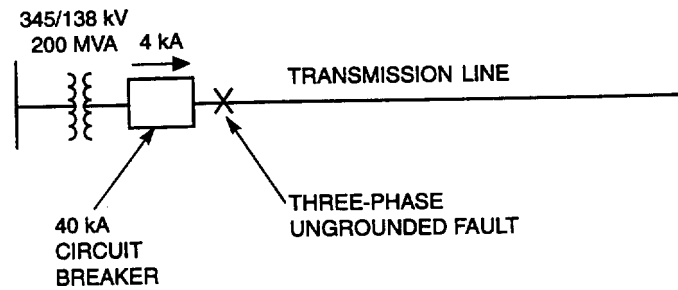

Figure 13—Fault location

The standard capability curve shown in figures 14 and 15 is defined by a one-cosine curve as follows:

$$e_2 = \frac{E_2}{2} [1 - \cos(\pi t / T_2)]$$

where E_2 and T_2 as defined in table 3 of ANSI C37.06-1987 for rated current and maximum voltage ($E_{\max} = 145 \text{ kV}$) are as follows:

$$E_2 = 1.76 E_{\max} = 255 \text{ kV}$$

$$T_2 = 310 \mu\text{s}$$

The factors for 10% current from table 6 in ANSI C37.06-1987 are as follows:

$$K_1 = 1.16$$

$$K_f = 5$$

TRV capability for 10% current is as follows:

$$E_2 = 296 \text{ kV}$$

$$T_2 = 62 \mu\text{s}$$

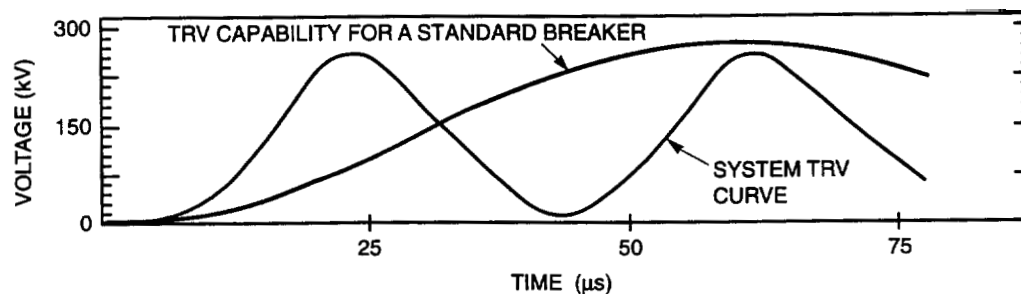
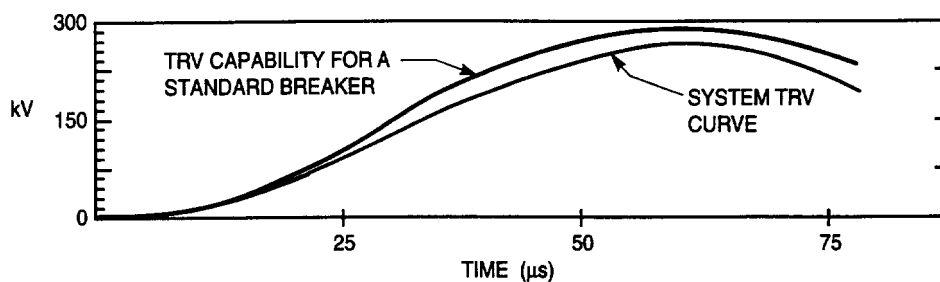

Figure 14—System and circuit breaker TRV curves



Same system as in Figure 13, but with additional capacitance between circuit breaker and transformer.

Figure 15—System and circuit breaker TRV curves

The exponential portion of the capability curve is zero for this current value. The constants are given in ANSI C37.06-1987 as explained in 4.2.1. It should be noted that the transformer limited fault can occur in a well developed substation, not just the radial system shown in figure 13. A similar condition could occur in the system of figure 10 if transformer breaker “C” was the last one to clear a bus fault with breaker “B” open.

4.4.2 Reactor limited fault

When line side series reactors are used, high rate-of-rise TRVs can result in much the same ways as for transformer limited faults discussed in 4.4.1. An example of a series reactor used on a 230 kV system is illustrated in figure 16. The resultant TRV for the case described is shown in figure 17. This system TRV exceeds the standard capability curve, which is described by a 1-cos curve as follows:

$$e_2 = \frac{E_2}{2} [1 - \cos(\pi t / T_2)]$$

where

$$\begin{aligned} E_2 &= 1.76 E_{\max} = 426 \text{ kV} \\ T_2 &= 520 \mu\text{s} \end{aligned}$$

The factors for 10% fault current from table 6 in ANSI C37.07-1987 are as follows:

$$\begin{aligned} K_1 &= 1.16 \\ K_f &= 5 \end{aligned}$$

The TRV capability for 10% current is as follows:

$$\begin{aligned} E_2 &= 494 \text{ kV} \\ T_2 &= 104 \mu\text{s} \end{aligned}$$

Wavetraps used in transmission line communication systems may also add a high frequency component to the TRV although of a lesser magnitude than a transformer or a current limiting reactor. However, under some circumstances, wavetraps can substantially increase the TRV over that present without the trap. A wavetraps is usually a parallel L-C device that is placed between the line and circuit breaker.

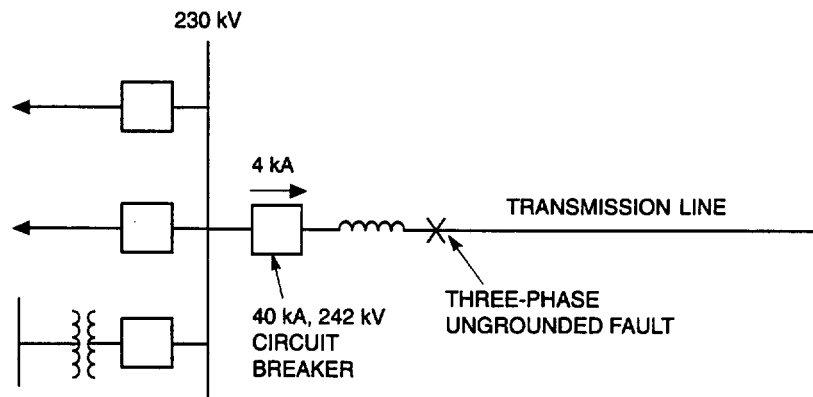

Figure 16—Fault location

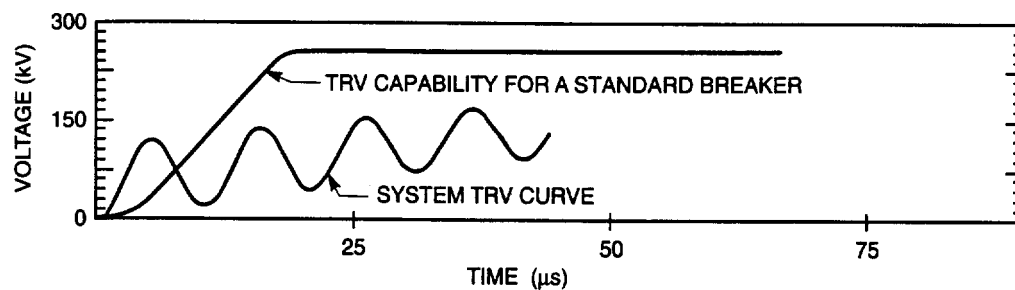

Figure 17—System and circuit breaker TRV curves

4.5 Applications where breaker capability is exceeded

When the inherent TRV of the system exceeds standards, the user has three main alternatives outside of reconfiguring the system. They are the following:

- A breaker with a higher rated interrupting rating, a higher voltage rating, or a modified circuit breaker should be used.
- Capacitance should be added to the circuit breaker terminal(s) to reduce the rate of rise of the TRV.
- The manufacturer should be consulted concerning the application.

As long as a circuit breaker is applied within its symmetrical current and voltage ratings, one of the above methods should result in a satisfactory application.

Annex A TRV calculation techniques

(Informative)

A typical system is shown in figure A.1 consisting of local sources and remote sources connected through transmission lines. This system will be used to illustrate the TRV types and calculation procedures. Four transmission lines and two transformers (local generation and a tie line transformer) supply the 138 kV station. A number of references are available on calculating TRVs (see [B1] through [B5], [B7] through [B9], and [B11] through [B13])⁴ in addition to the information in this annex. [B2] gives a basic discussion of TRVs while the papers referenced deal with specific problems and concerns as well as more complex applications.

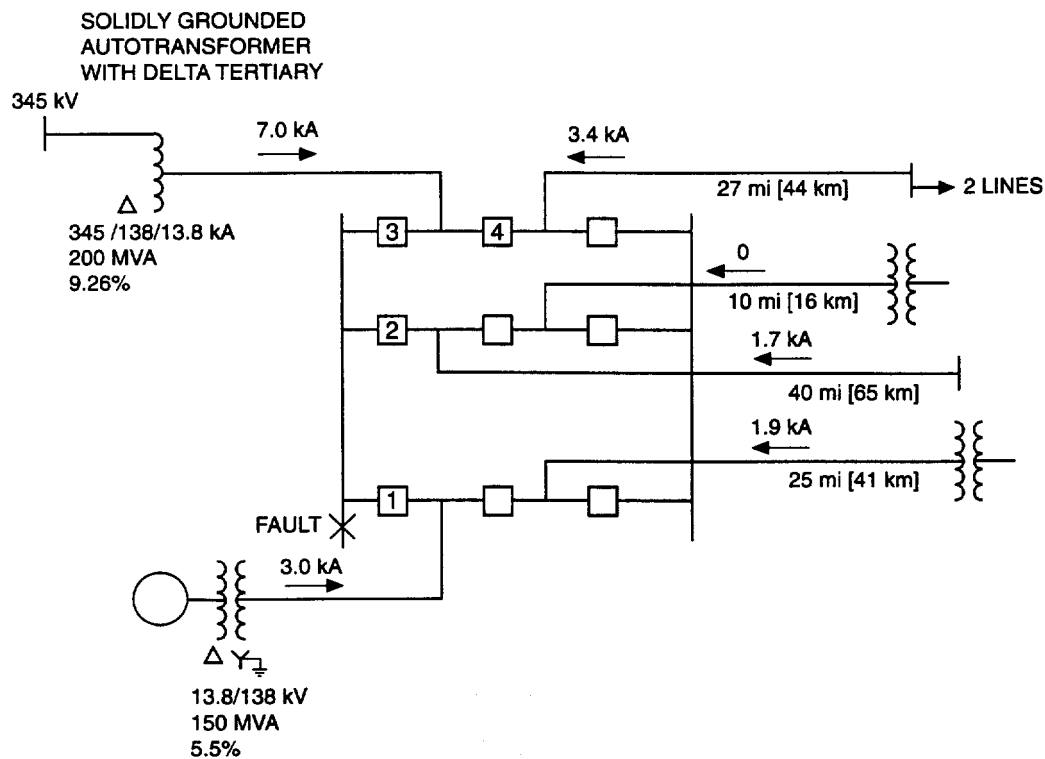

Figure A.1—System diagram

A.1 Transient recovery voltage types

Three-phase ungrounded terminal faults and short line faults will be discussed. The ungrounded fault discussion is further divided into terminal faults having oscillatory and exponential waveforms. The three-phase ungrounded fault is usually the most severe terminal fault type and is used to define the breaker rating. Short line faults generally have higher rates of rise of recovery voltage than do terminal fault TRVs but have lower crest voltage magnitudes [B11], [B13].

⁴The numbers in brackets correspond to those bibliographical items listed in annex C.

A.1.1 Three-phase ungrounded fault

During the interruption of a three-phase ungrounded fault, the circuit shown in figure A.2a) defines the general electrical equivalent network for the first phase to clear. The reduced circuit is valid for short time frames until reflections return from remote buses. Reflections are covered in A.1.2. Figure A.2a) shows a one-line diagram representation, while figure A.2b) indicates the three-phase representation. Figures A.2c) and A.2d) are equivalent circuits and show that the problem reduces to a simple parallel RLC circuit.

The Z_s term is equal to Z_1/N

where

Z_1	is the positive-sequence surge impedance of the transmission lines terminating at the station
N	is the number of lines
L_s	is the positive-sequence equivalent local inductance, representing all other parallel sources terminating at the station (transformation to lower or higher voltage systems, generation, etc.)
C_s	is the total positive-sequence phase-to-ground shunt capacitance
V_{cb}	is the voltage across the open circuit breaker contacts

These parameters are discussed in later subclauses.

A.1.1.1 Exponential (overdamped) TRV

Current injection techniques can be used to solve for the circuit breaker TRV and, because the time span of interest is short (microseconds), the interrupted current can be represented by a ramp. The solution for the parallel RLC network as shown in figure A.2d) is

$$V_{cb} = E_1 \left[1 - e^{-\alpha t} \left(\cosh \beta t + \frac{\alpha}{\beta} \sinh \beta t \right) \right] \text{ kV} \quad (\text{A-1})$$

where

E_1	is $1.5 \cdot 1.5 \sqrt{2} I \omega L_s$ in kV
ω	is $2\pi f = 377$ rad/s for 60 Hz systems
I	is short circuit current in kA, rms
α	is $1/(2Z_s C_s)$
β	is $\sqrt{\alpha^2 - 1/(L_s C_s)}$
Z_s	is Z_1/N in Ω ; N is the number of lines
L_s	is in henrys
C_s	is in farads

For many systems the circuit will be overdamped by the parallel resistance of the line surge impedances, thus the capacitance can be neglected as a first approximation. The solution to the simple RL circuit is then

$$V_{cb} = E_1 (1 - e^{-t/\tau}) \text{ kV} \quad (\text{A-2})$$

where

$$\tau \text{ is } (1.5 L_s)/(1.5 Z_s) \text{ or } L_s/Z_s \text{ s}$$

The derivative of equation A-2 at time zero is the rate of rise of the recovery voltage and is given by

$$\frac{dV_{cb}}{dt} = R = 1.5 \sqrt{2} I \omega Z_s \cdot 10^{-6} \text{ kV}/\mu\text{s} \quad (\text{A-3})$$

The above exponential expressions [see equations (A-1), (A-2), (A-3)] describe the component of the TRV until reflections return from remote stations associated with the transmission lines connected to the faulted station.

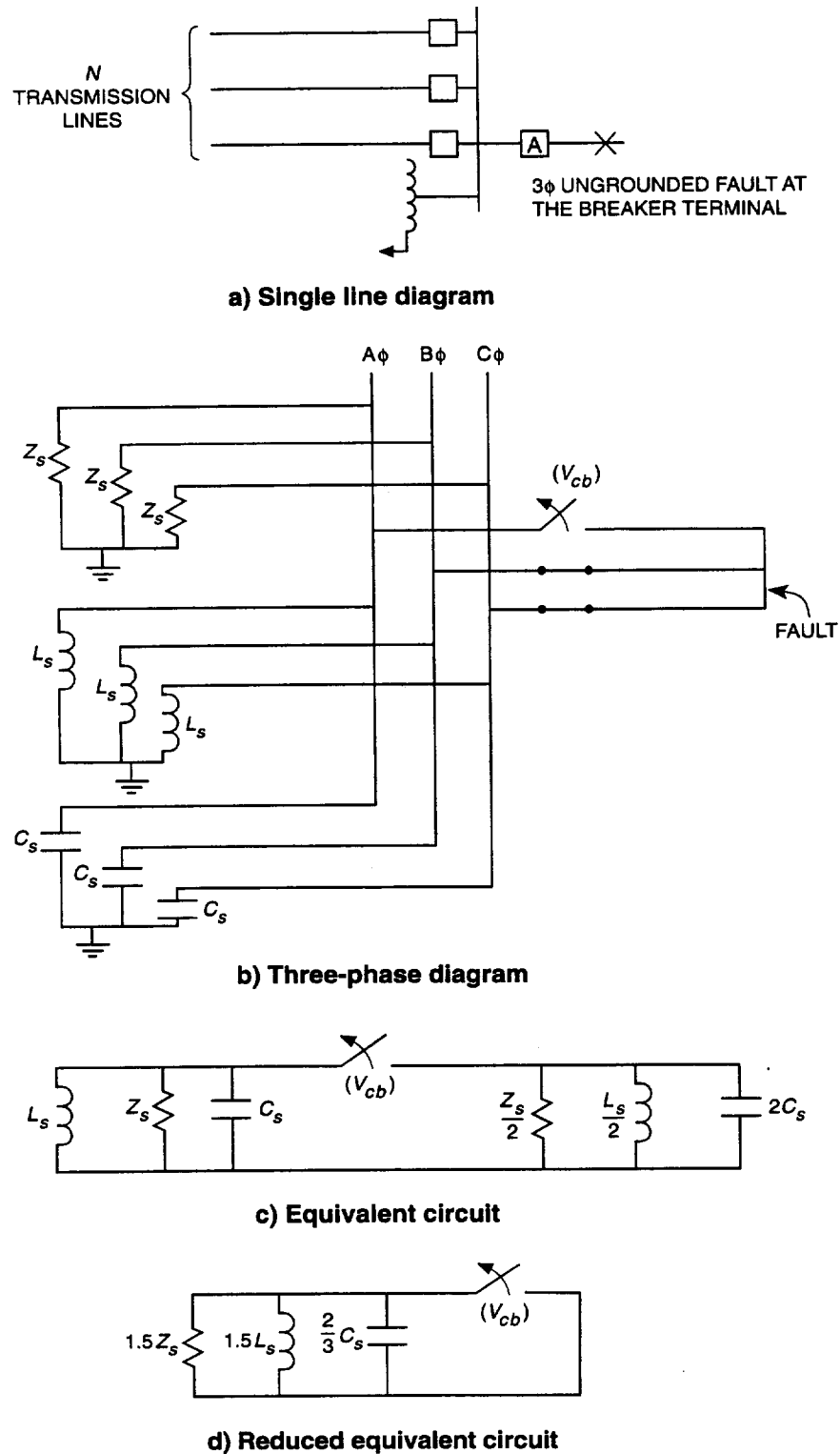

Figure A.2—Circuit definition—interruption of a three-phase ungrounded fault

A.1.1.2 Oscillatory (underdamped) TRV

If there are no lines on the bus, then the resistance is removed from the equivalent circuit in figure A.2d), and the TRV will be oscillatory. An approximate expression for the voltage is given in equation (A-4). The expression is approximate because of neglecting the source impedances behind the transformers.

$$V_{cb} = E_1[1 - \cos(t/\sqrt{L_s C_s})] \text{ kV} \quad (\text{A-4})$$

Even when lines are present, it is possible for the recovery voltage to be oscillatory. To be oscillatory, the surge impedance of a source side line has to be such that

$$Z_s = > 0.5\sqrt{L_s/C_s}$$

where

$$Z_s = \frac{Z_1}{N} \quad (\text{A-5})$$

This formula shows that as the number of transmission lines is increased, the circuit is likely to be nonoscillatory, i.e., overdamped. In most cases, however, even $N=1$ makes the circuit overdamped.

A.1.2 Reflected waves

The initial wave that was calculated in equation (A-2) appears across the breaker pole. It also appears as traveling waves on each of the transmission lines. When one of these waves reaches a discontinuity on the line such as another bus or a transformer termination, a reflected wave is produced, which travels back towards the faulted bus. The time for a wave to go out and back to a discontinuity is

$$T_s = 10.7 l\sqrt{\mu k} \mu\text{s} \quad (\text{A-6})$$

l is miles to the first discontinuity
 μ is permeability
 k is dielectric constant

for overhead lines

$$\sqrt{\mu k} = 1.0$$

for cables, typically $k = 4$

$$\mu = 1.0, \sqrt{\mu k} = 2$$

At a discontinuity transmitted and reflected waves can be described by equations (A-7) and (A-8) and figure A.3 [B1], [B6].

Transmitted wave

$$e_t = e_i[2Z_2/(Z_1 + Z_2)] \quad (\text{A-7})$$

Reflected wave

$$e_r = e_i[(Z_2 - Z_1)/(Z_1 + Z_2)] \quad (\text{A-8})$$

where

e_i is the incident wave
 Z_1 and Z_2 are the effective surge impedances on either side of the discontinuity

Returning to the bus, the reflections are in turn reflected to begin the process again (see [B3] and [B5]). A typical TRV, including the first reflection, is shown in figure A.4.

[B5] shows that a reflected wave returning from an open ended line will contribute to the bus side TRV as follows:

$$E_{rl} = E_1 \frac{2Z_s}{NL_s} t e^{-Z_s t/L_s} \text{ kV} \quad (\text{A-9})$$

In [B5] it is suggested that the maximum reflected voltage is $E_{rl} \text{ max} = 0.7 E_1/N$ (due to damping, etc.). The more lines connected, the lower the magnitude of the reflected wave.

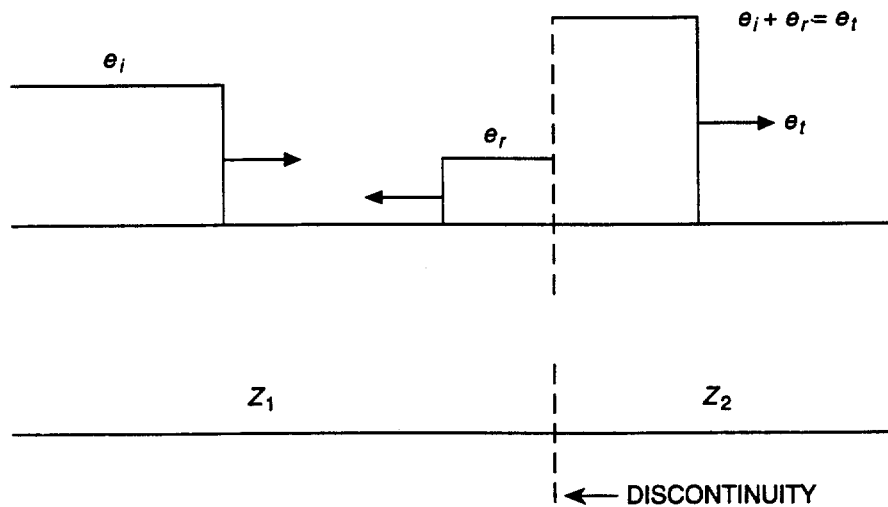

Figure A.3—Traveling waves at discontinuity

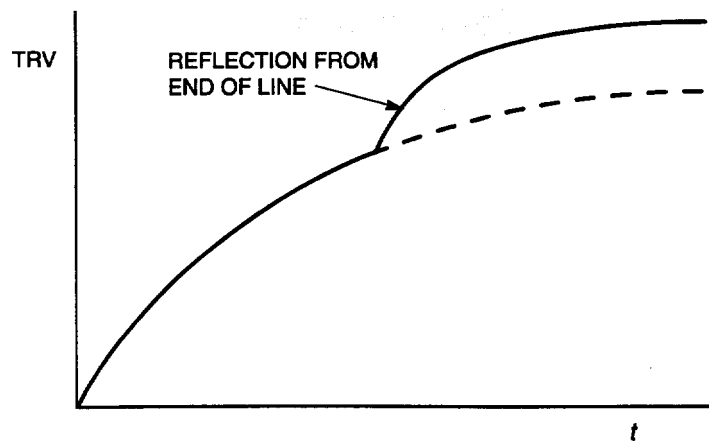

Figure A.4—Typical TRV including the first reflection

A.1.3 Short-line fault

Triangular-shaped recovery voltages are associated with line faults. Because cables and overhead lines have distributed constants, the line side voltage oscillates in the form of a traveling wave with positive and negative reflections at the open breaker and at the fault, respectively. The line side component of the recovery voltage has a sawtooth shape and a high rate of rise. Generally, the source recovery voltage rises much more slowly and only the line side triangular recovery voltage is important during the early portion of the TRV. As the fault is located closer to the circuit breaker, the initial rate of rise of the line side recovery voltage increases due to the higher fault current, while the crest magnitude of this line side triangular wave decreases due to the shorter time for the reflected wave to return.

The fault current for a line side fault is somewhat reduced from that obtained for a bus fault due to the additional reactance of the line. Let I_T be the fault current through the breaker for a single-phase bus fault at the breaker terminal, and I_L be the reduced current for a line fault. The fault current is

$$I_L = \frac{V_{LG}}{X_L + V_{LG}/I_T} \text{ kA, rms} \quad (\text{A-10})$$

where

- X_L is $1/3 (X_{1L} + X_{2L} + X_{0L}) \Omega$
- X_L is the reactance of the transmission line to the fault point
- X_{1L} is the positive sequence line inductive reactance
- X_{2L} is the negative sequence line inductive reactance
- X_{0L} is the zero sequence line inductive reactance
- V_{LG} is the system line-ground voltage in kV, rms

The TRV rate of rise (R) of the line side TRV for a short line fault is equal to the effective line side surge impedance (Z) multiplied by the slope of the current at current zero as follows:

$$R = \sqrt{2} \omega I_L Z 10^{-6} \text{ kV}/\mu\text{s} \quad (\text{A-11})$$

The line side recovery voltage will crest in

$$T_C = l \cdot t_L \mu\text{s} \quad (\text{A-12})$$

where

- l is the distance from the breaker to the fault in miles
- t_L is twice the travel time of 1 mi (1.61 km) of line (10.7 μ s for an overhead line)

The line side recovery voltage crest will be equal to

$$T_c \cdot R \text{ kV} \quad (\text{A-13})$$

The effective surge impedance is a function of both the positive and zero sequence surge impedances and is influenced by bundle and tower configuration. Typical values for different voltage class lines are presented in A.2.5.

A.2 Equivalent circuit representation

In the calculation of inherent TRVs, it is first necessary to determine the effective inductances and capacitances at the frequencies of the TRV near the circuit breaker location. Next, the line and cable equivalents are determined by their surge impedance, length, and remote terminations and interconnections. The equivalent three-phase circuit representation of the transient system can be calculated using these parameters. From this representation, the circuit transient recovery voltages can be determined as indicated in A.3. The following examples in A.2.1 illustrate the various techniques for the reduction of system elements to equivalent transient circuits.

When three-phase faults are being examined, it is only necessary to include the positive-sequence components. For greater accuracy, the zero sequence network can be included. The circuit is modified to include zero-sequence components when the single-phase grounded fault is analyzed.

A.2.1 Examples of system inductance determination

The examples that follow are based on the system and characteristics shown in figure A.1.

A.2.1.1 Transformer equivalent

The reactive ohmic values and normal frequency inductive values are calculated from equipment data as follows:

$$\text{Reactance} = \frac{(\text{kV}_{L-L})^2}{\text{MVA}} \cdot X$$

where

the impedance X is given in per unit

For the autotransformer used in the example (see figure A.1),

$$\text{Reactance} = \frac{138^2}{200}(0.0926) = 8.8\Omega$$

For the generator step-up transformer,

$$\text{Reactance} = \frac{138^2}{150}(0.055) = 7.0\Omega$$

A.2.1.2 Line equivalents

The positive-sequence reactance of the 138 kV overhead line is assumed to be 0.80 Ω /mi (0.5 Ω /km).

A.2.1.3 Line termination equivalent

For the 138 kV system in figure A.1, the line terminations are determined from equipment characteristic data or from a lumping of system parameters at a multi-element termination (see figure A.5). The positive-sequence reactance of the generator is given as 19.6Ω . The reactive equivalent of the 345 kV system is 2.6Ω . The terminal reactive equivalents at the end of the 27-mi (44 km), 40-mi (65 km), and the 25-mi (41 km) lines are 2.0Ω , 16.0Ω , and 22.0Ω , respectively. The 10-mi (16 km) line is load terminated at a unit substation, contributes no fault current, and is considered an open circuit.

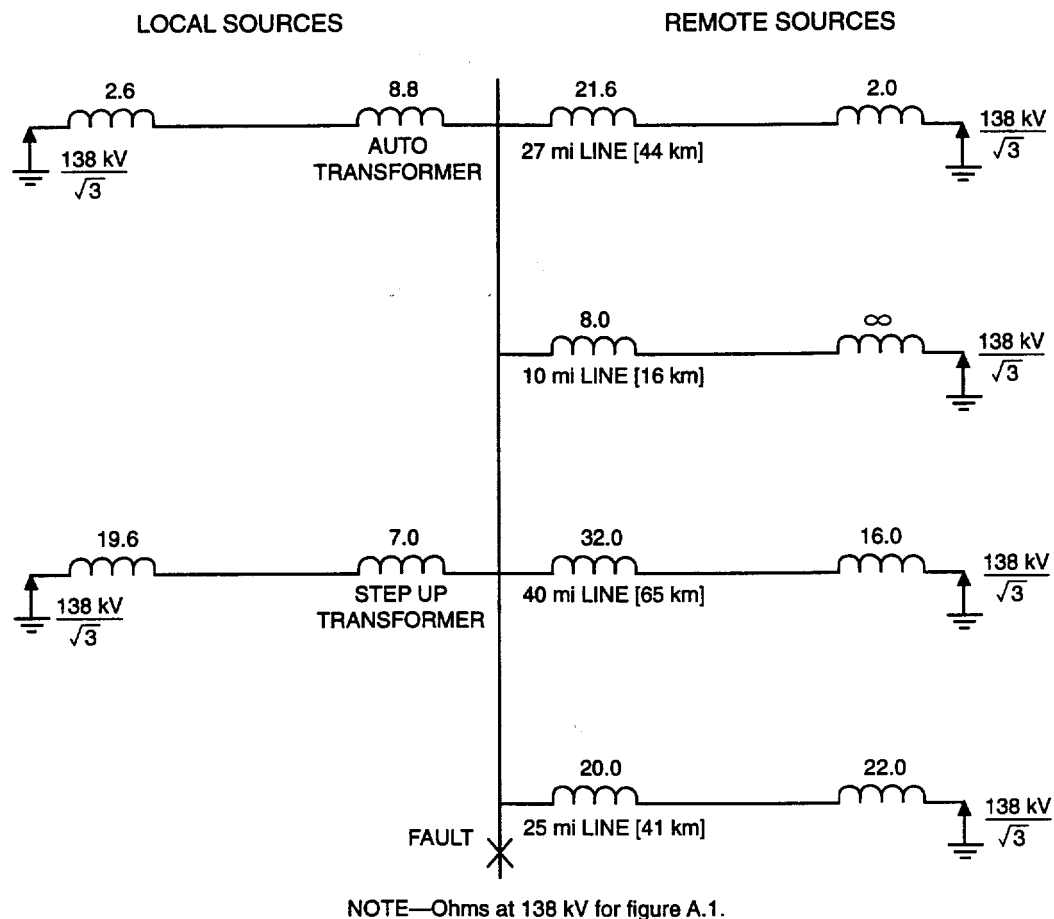

Figure A.5—System reactive ohms and effective voltages

A.2.2 Calculation of short-circuit currents

The short-circuit current associated with each local and remote source is calculated as indicated in 5.3 of IEEE Std C37.010-1979.

A.2.2.1 Total short-circuit current calculation

Using the reactances calculated in A.2.1, the total short-circuit current is equal to the line-to-neutral system voltage divided by the system reactance at the fault location. As an example, a fault at the 138 kV bus is illustrated in figure A.1 as follows:

$$\text{Total short-circuit current} = \frac{138/\sqrt{3} \text{ kV}}{4.7 \Omega} = 17 \text{ kA}$$

A.2.2.2 Individual source short-circuit current calculation

The total short-circuit current is supplied by the contributions from the individual sources. For a fault at the 138 kV bus, the short-circuit current contribution of the autotransformer is as follows:

$$\frac{138/\sqrt{3} \text{ kV}}{(2.6 + 8.8)\Omega} = 7 \text{ kA}$$

The fault current contribution from each branch is given in figure A.1.

A.2.3 Effective local source inductance

The effective local source inductance L_S , as illustrated in figure A.2, is the parallel combination of the inductances that are active in producing the TRV. In the frequency ranges of concern, equipment capacitances and line surge impedances often have the effect of shorting the transformer terminal opposite the circuit interrupting device and, thus, eliminating the effect of system inductance. That is, the high side frequency is generally slower than the transformer component and is not significant during the period of interest [B2]. That response is assumed in this example. Using the transformer reactances calculated in A.2.2.1

$$\begin{aligned} \text{Inductance (autotransformer)} &= \text{Reactance}/(2\pi f) \\ &= 8.8/377 = 0.023 \text{ H} \end{aligned}$$

$$\text{Inductance (generator transformer)} = 7.0/377 = 0.018 \text{ H}$$

$$L_S = (0.023)(0.018)/(0.023 + 0.018) = 0.010 \text{ H}$$

A.2.4 Effective capacitance

Typical equipment capacitance values are given in annex B. The total substation capacitance is labeled as C_S in figure A.2. It is determined by summing the equipment capacitance.

A.2.4.1 Station capacitance equivalent

The single-phase station capacitance, excluding power transformers, consists of the following assumed equipment (see table A.1). The fault side capacitance is neglected because it is small. Operating breaker capacitance is not included because the intent is to produce the inherent TRV generated external to the operating breaker.

Table A.1—Single-phase station capacitance

4 Dead-tank oil circuit breakers (closed) · 600 pF each	= 2400 pF
2 Live-tank air circuit breakers (closed) · 100 pF each	= 200 pF
2 Live-tank air circuit breakers (open) · 50 pF each	= 100 pF
4 Current transformers · 300 pF each	= 1200 pF
193 ft (59 m) bus and switches · 3.0 pF/ft (0.9 pF.m)	= 580 pF
12 Disconnect switches (closed) · 90 pF each	= 1080 pF
2 Potential transformers · 400 pF each	= 800 pF
1 Current limiting reactor · 200 pF	= 200 pF
Total	6560 pF

A.2.4.2 Transformer capacitance equivalent

Transformer capacitances often make up a significant part of the total at a given bus; however, they are often difficult to determine especially in the planning stage. A more detailed discussion is given in annex B. For the transformer in this example, the following single-phase, line-to-ground capacitances are assumed:

Autotransformer capacitance = 3200 pF

Generator transformer capacitance = 2440 pF

A.2.5 Line and cable equivalent

The line and cable surge impedances (Z) for line transient consideration appear as resistances and may be calculated using techniques developed by Carson and others. They may be approximated as summarized in table A.2.

Table A.2—Surge impedances

	System (kV)	Z_1^* (Ohms)	Z_{eff}^\dagger (Ohms)
Overhead lines	138	350	420
	230	375	425
	345 [‡]	280 [‡]	330 [‡]
	500 [‡]	280 [‡]	330 [‡]
	765 [‡]	265 [‡]	310 [‡]
Cables	69	Cable surge impedance depends on the cable type and configuration. Typically Z_1 and Z_{eff} range from 50 to 75 Ω with $Z_1 \cong Z_{eff}$	
	138		
	230		
	345		
SF ₆ buswork	All voltages	55	55

*Used for three-phase ungrounded terminal faults.

†Used for short line faults where $Z_{eff} = \frac{2Z_1 + Z_0}{3}$ and Z_0 is determined at switching surge frequencies.

‡Bundled conductors assumed for 345 kV class lines and above.

For the example, a surge impedance of $350\ \Omega$ was assumed for each line. The effective surge impedance for all four lines at the 138 kV bus is $Z_s = 350/4 = 87.5\ \Omega$. This representation of the lines is correct until the first wave reflection from the nearest remote terminal is received.

A.3 Example of transient recovery voltage calculation

Using the system shown in figure A.1 and the equivalent circuits determined in A.2, the TRVs are calculated for a bus fault and for a short line fault.

A.3.1 Three-phase ungrounded terminal fault

For the first phase to clear a three-phase ungrounded fault as labeled in figure A.1, the equivalent circuit for the last breaker to clear the fault is shown in figure A.6. The equivalent transformer inductance is 10 mH (see A.2.3). The total equivalent capacitance is 12 200 pF (see A.2.4). The surge impedance for the four lines is $88\ \Omega$ (see A.2.5). The circuit will be oscillatory if the conditions given in A.1.1.2 are satisfied as follows:

$$\frac{Z_1}{N} > 0.5 \sqrt{L_s/C_s}$$

or

$$Z > 0.5 \sqrt{L/C}$$

$$132 > 0.5 \sqrt{(0.015)/(8.13 \cdot 10^{-9})}$$

$$132 > 679$$

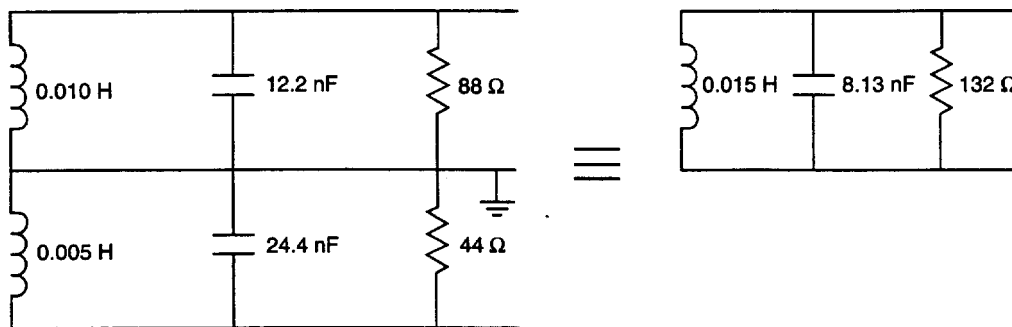

NOTE—See figure A.2c) as a reference.

Figure A.6—Equivalent circuit—Last pole to clear

Because the conditions are not met, the circuit is not oscillatory and the exponential solution form (either the hyperbolic or the simplified form given in A.1.1.1) is applicable.

The shunt capacitance essentially results in a delay at the start of the exponential TRV. The amount of the delay is equal to ZC , which in this case amounts to the following:

$$ZC = (1.5Z_s)(C_s/1.5) = 132(8.13 \cdot 10^{-9})$$

$$= 1.1 \mu\text{s}$$

This delay is small and can be neglected. Note that for other conditions, such as when only one line is connected, the delay will be more significant due to the increased Z .

For the example, the delay is small, the capacitance can be neglected, and the following simplified exponential form can be used:

$$V_{cb} = E_1(1 - e^{-t/\tau})$$

$$E_1 = 1.5\sqrt{2} I \omega L_s$$

$$= 1.5\sqrt{2}(17)(377)(.010)$$

$$= 136 \text{ kV}$$

$$\tau = L_s/Z_s = .010/88$$

$$= 114\mu\text{s}$$

$$V_{cb} = 136(1 - e^{-t/114 \cdot 10^6}) \text{ kV}$$

The rate of rise of the TRV is

$$R = 1.5\sqrt{2} \cdot I \cdot \omega \cdot Z_s \cdot 10^{-6} \text{ kV}/\mu\text{s}$$

$$= 1.5\sqrt{2}(17)(377)(88)(10^{-6})$$

$$= 1.2 \text{ kV}/\mu\text{s}$$

The resultant TRV for the circuit of figure A.6 is illustrated in figure A.7. This, then, is the TRV, which acts as a traveling wave, and will be transmitted down each line connected to the station. As this wave reaches the remote termination of the line, it will be reflected. The reflected wave will return to the faulted station and will be superimposed on the circuit breaker TRV.

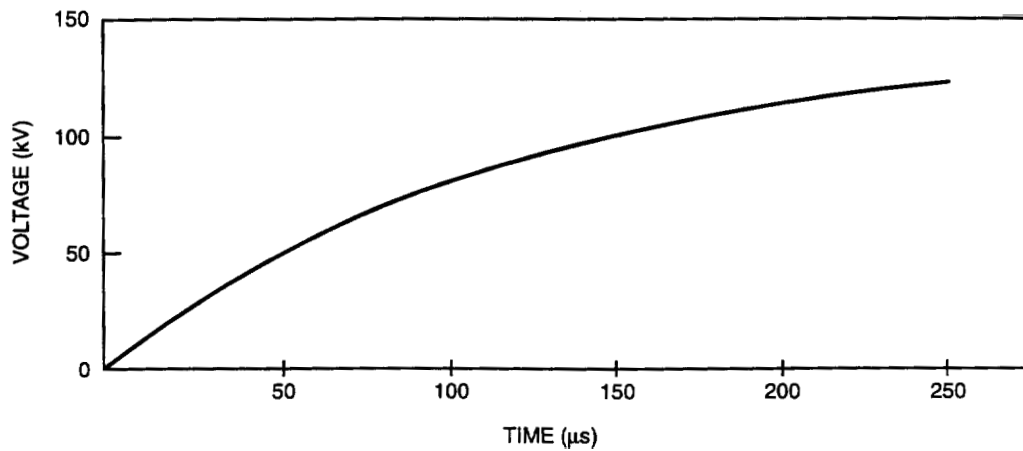

Figure A.7—Breaker TRV for circuit of figure A.6

The first reflection will come back from the shortest line, which is 10 mi (16.1 km) long. Since this line is transformer terminated, it can be considered an open circuit (i.e., $Z_2 = \infty$, as illustrated in figure A.3). The reflected wave front will then be identical with and superimposed on the incoming wave. In actuality, the transformer will initially appear as an open circuit to surges and then change to a short circuit. This transposition is exponential, having a time constant of L of the transformer divided by the surge impedance of the line. Because the line is 10 mi (16.1 km) long, it will take 107 μs for the wave to be reflected back to the bus. The front of the wave will be positive and added to the original outgoing wave. The voltage at the remote transformer will be double that of the incident wave. That portion of the returning wave that will be *transmitted* through the bus and out on the other three lines (neglecting the effects of bus inductance and capacitance) is as follows:

$$e_t = e_i \left(\frac{2Z_2}{Z_1 + Z_2} \right) = e_i \left(\frac{2Z/3}{Z + Z/3} \right) = 0.50e_i$$

(See A.1.2).

The wave reflecting back on the line is

$$e_r = e_i \left(\frac{Z_2 - Z_1}{Z_1 + Z_2} \right) = e_i \left(\frac{Z/3 - Z}{Z + Z/3} \right) = -0.50e_i$$

The second reflection will enter the bus at 214 μs and will add to the line voltage. The TRV waveform, including the reflections for the first 250 μs , is illustrated in figure A.8.

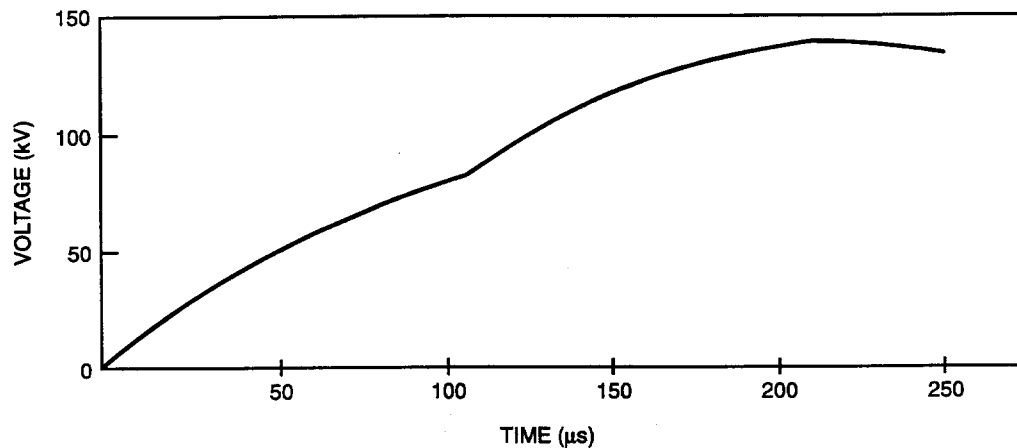

Figure A.8—Breaker TRV for circuit for figure A.6 with reflections

When the remote source inductance is considered, the transmitted voltage waves at the bus will be a more complex function of time (see [B5]). For an incident wave of $e_i = E_1(1 - e^{-Z_s t/L_s})$ the first transmitted wave is of the following form:

$$e_t = \frac{2Z_s E_1}{NL_s} t e^{-Z_s t/L_s}$$

where

L_s is the source inductance
 N is the number of transmission lines connected to the bus

The inclusion of the remote transformer inductance will tend to reduce the TRV and may be sufficient to make marginal breaker applications suitable.

The first reflections from the 27 mi (43.5 km), 40 mi (64.4 km), and 25 mi (40.2 km) lines will return at 289 μs, 428 μs, and 268 μs, respectively. These reflections may add or subtract from the total TRV, depending upon the type of termination at the remote ends of the lines.

A.3.2 Three-phase ungrounded terminal fault—Autotransformer breaker last to clear

The equivalent circuit for the opening of the autotransformer breaker, assuming circuit breaker 3 (as illustrated in figure A.1) is the last to open, is as shown in figure A.9. Breaker 4 is assumed open prior to the fault with 1 and 2 already having cleared. The capacitance of the transformer plus that of the bus, disconnect switch, etc. is assumed to be 3228 pF. The simpler equivalent circuit is given in figure A.10, and the corresponding TRV is illustrated in figure A.11 for the following parameters:

$$\text{Time to crest} = \pi\sqrt{LC}$$

$$= \pi\sqrt{(0.0351)(2152 \cdot 10^{-12})}$$

$$= 27.3\mu\text{s}$$

$$V_{CB} = 2 \cdot \sqrt{2} \cdot \omega \cdot I \cdot L_{s1}$$

$$= 2 \cdot \sqrt{2} \cdot 377 \cdot 7 \cdot 35.1$$

$$= 262 \text{ kV}$$

$$\text{Average rate of rise} = \frac{260.0 \text{ kV}}{27.3\mu\text{s}} = 9.6 \text{ kV}/\mu\text{s}$$

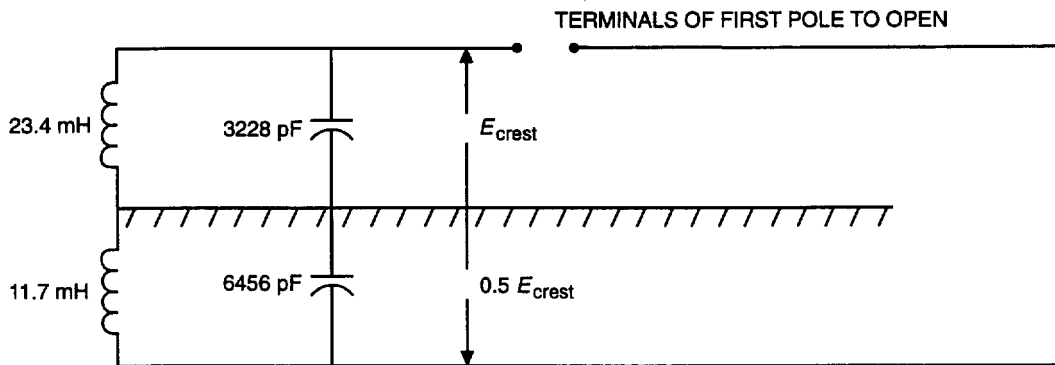

Figure A.9—Transient equivalent for the tie transformer bus fault

A.3.3 Single-phase short line fault

A single line-to-ground fault is evaluated at two miles from the substation illustrated in figure A.1 on the 10 mi (16.1 km) long line (see A.1.3). The key parameters assumed for this evaluation are given as follows:

- The single line-to-ground bus fault is 17 kA, which is the same as the three-phase bus fault.
- The positive and zero sequence line impedances are $X_1 = 0.8 \Omega/\text{mi}$ ($0.5 \Omega/\text{km}$) and $X_0 = 2.0 \Omega/\text{mi}$ ($1.2 \Omega/\text{km}$).

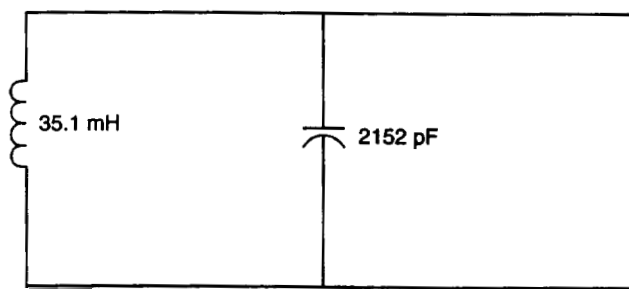

Figure A.10—Transient equivalent of figure A.9

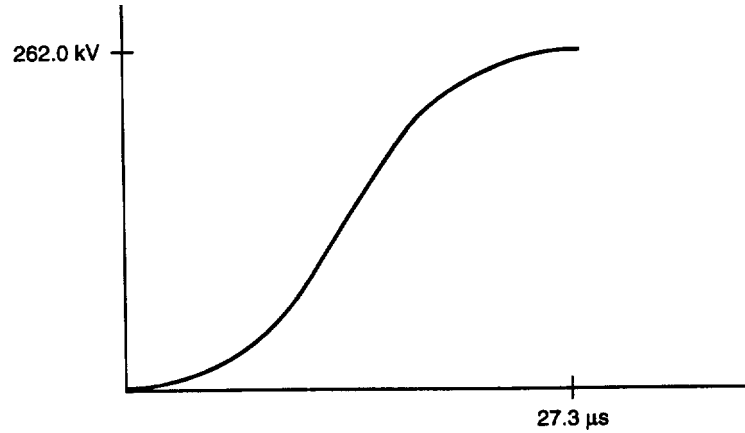

Figure A.11—Breaker TRV for figure A.10

Using equation A-10, the single line-to-ground fault current at 2 mi (3.2 km) from the substation is determined as follows:

$$I_L = \frac{138/\sqrt{3}}{1.2 + 4.7} = 13.5 \text{ kA}$$

Using a value of 420 Ω for the effective line side surge impedance (see table A.1), the line side component is a sawtooth wave with a slope of

$$\begin{aligned} R_{\text{line side}} &= \sqrt{2} \cdot 13.5 \cdot 377 \cdot 420 \cdot 10^{-6} \text{ kV}/\mu\text{s} \\ &= 3.02 \text{ kV}/\mu\text{s} \end{aligned}$$

and will crest in $10.7 \cdot 2$ or $21.4 \mu\text{s}$.

The TRV effective inductance is assumed to be equal for both the positive and zero sequences. Therefore, $L = 0.010 \text{ H}$. The source side component, assuming capacitance can be neglected is as follows:

$$\begin{aligned} V_{\text{source side}} &= E_1(1 - e^{-t/\tau}) \text{ kV} \\ E_1 &= \sqrt{2} I \omega L_{\text{eff}} \\ &= \sqrt{2} \cdot 13.5 \cdot 377 \cdot 0.010 \\ &= 72 \text{ kV} \end{aligned}$$

The time constant, τ , of the source side TRV is

$$\tau = L_{\text{eff}}/Z$$

$$= 0.010 / (420 / 3)$$

$$= 71.4 \mu\text{s}$$

Therefore, $V_{\text{source side}} = 72 (1 - e^{-t/71.4 \mu\text{s}})$ kV

The source side, line side, and total TRV are shown in figure A.12

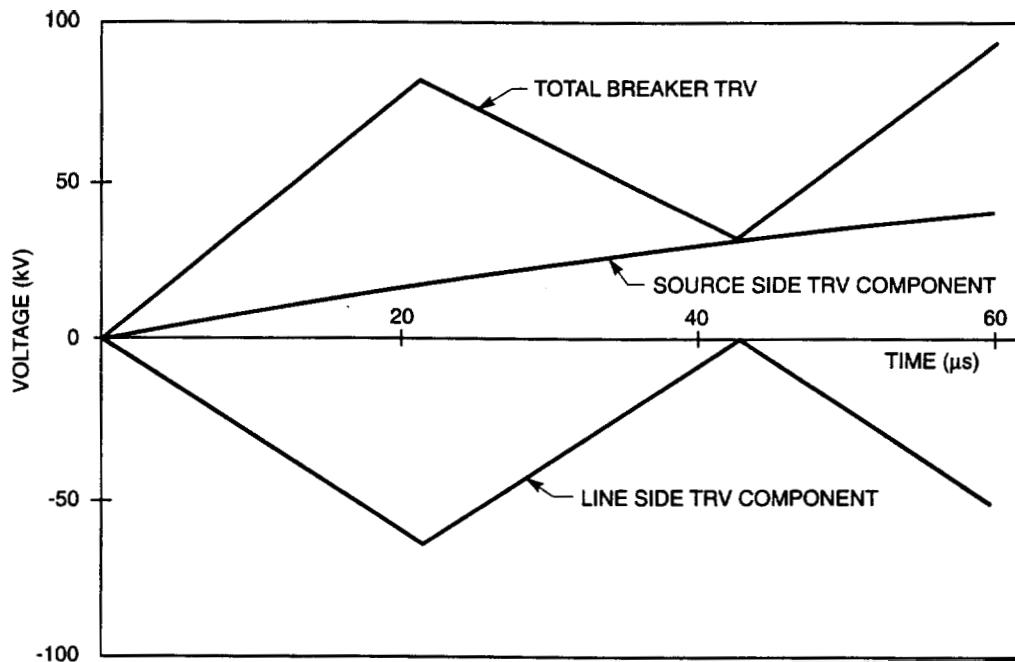

Figure A.12—Short-line fault TRV

If the TRV duty is excessive, capacitance to ground can be added on the line side of the breaker to reduce the rate-of-rise of the TRV. For heavy fault currents, conductor clashing may occur when bundled conductors are used. In this case, the effective line surge impedance will increase, resulting in a higher TRV. A detailed discussion of added capacitance and bundle clashing can be found in [B4] and [B9].

Annex B Typical capacitance values for various equipment

(Informative)

In the calculation of TRVs, circuit constants should be supplied for each of the elements on the system. In general, only inductances and capacitances are needed; resistance can be neglected. Accurate information on the inductance of apparatus is given by the manufacturer, but little or no information is given on the effective capacitance of apparatus.

The effective value of capacitance is the lumped value at the terminals that is equivalent to the distributed capacitance of the apparatus in the frequency range of the recovery voltage. In many cases, there may not be an opportunity to measure the effective capacitance of the equipment to be used. Tables B.1 through B.9 of this annex provide a guide for estimating the effective capacitance of various apparatus. The range of data is wide but in many cases it is suitable for estimating the TRV.

In those cases where more accurate capacitance values are needed, values should be determined by measurement or calculation. It is possible to calculate effective capacitance from simple apparatus geometry, e.g., GIS bus. It is also possible to calculate effective capacitance from low-frequency measurements of capacitances combined with apparatus geometry, e.g., reactors and transformers, but these calculations are complex and beyond the scope of this annex, and caution should be used in applying the results.

The effective capacitance can be evaluated by measuring the natural frequency of the apparatus under specified fault conditions. The natural frequency can be determined by low-voltage current injection to excite the system by variable-frequency resonant measuring circuitry and by measurement of the TRV during interruption of short-circuits at full or reduced voltage. The effective capacitance can then be evaluated using the inductance of the apparatus and the measured natural frequency.

The effective capacitances of several items in parallel can be simply summed to yield a total effective capacitance that can then be combined with the effective inductance for TRV calculations. In those cases of oscillatory transients where the total capacitance is large, e.g., more than 10 times the effective capacitance of the current limiting apparatus, the effect of the wide range of capacitances in the tables is small and the resulting frequency is accurately predicted. In those cases where only a few pieces of apparatus are connected, the large range of capacitance results in a wide range of estimated TRV frequencies.

The interruption of fault currents limited by transformers without additional capacitance between the transformer and the circuit breaker results in very high TRV frequencies that impose severe duty on the circuit breaker. These frequencies have been extensively measured by several investigators [B8] , [B10] , [B12] . Figures B.1 and B.2 show the 50th and 90th percentile frequencies vs. fault current for maximum system voltages from 15 kV to 550 kV. The graphs are based on transformer-limited faults supplied by an infinite source. It is recommended that these graphs be used to estimate TRV frequencies of transformer limited faults and to calculate the effective capacitances more accurately from those frequencies when required.

Table B.1—Effective generator capacitance (per phase)

	Generator size (MVA)	Capacitance (nF)
Steam-turbine driven	15–70	30–85
	70–300	50–110
	300 and up	65–250
Hydro driven	10–25	50–85
	25–100	150–300
NOTE — There is no direct correlation between MVA size and capacitance limits. For instance, a 50 MVA generator may have a capacitance-to-ground anywhere from 30–85 nF depending upon machine design.		

Table B.2—Outdoor bushing capacitance

Maximum system voltage (kV)	Capacitance (pF)			
	Air-to-oil, air-to-SF ₆ laminated foil, oil and paper insulated	Air-to-SF ₆ , SF ₆ insulated	SF ₆ -to-oil, SF ₆ and oil insulated	Air-to-air, air-to-oil, air-to-SF ₆ , solid insulated
15–72.5	150–650	25–150	—	30–200
72.5–800	100–1200	25–150	100–500	100–500
NOTE — Larger values of capacitance are typically associated with higher voltages but there is a wide range at each voltage level. Not all types of bushings are made at every voltage level.				

Table B.3—Effective capacitance of inductive instrument transformer

Maximum system voltage (kV)	Outdoor potential transformers capacitance (pF)	Outdoor current transformer capacitance (pF)	SF ₆ insulated potential transformer for GIS capacitance (pF)
15–72.5	125–500	75–260	200–400 (Epoxy insulated)
72.5–800	150–450	150–450	70–150 (Laminated foil, SF ₆ insulated)

Table B.4—Capacitive voltage transformer capacitance

Voltage class (kV)	Capacitance (pF)
145	8000–16 000
242	8000–11 000
362	7000–11 000
550	4000–7000
800	2000–4000

Table B.5—Bus capacitance—Air insulated bus

Ampere rating	Isolated phase bus capacitance (pF/ft) (pF/m) up to 38 kV maximum system voltage	Segregated phase bus capacitance (pF/ft) (pF/m) 15 kV maximum system voltage	Outdoor substation bus capacitance (pF/ft) (pF/m)
1200–3500	8–16 (26–52)	10–20 (33–66)	2.5–5.5 (8.2–18.0)
4000–6500	12–19 (39–62)	10–20 (33–66)	2.5–5.5 (8.2–18.0)
7000–12000	14–24 (46–79)	—	—

Table B.6—Gas-insulated substation capacitance

Rated maximum voltage (kV)*	Isolated phase bus (pF/ft) (pF/m)	Three-in-one bus (pF/ft) (pF/m)†
242 and below	15–20 (49–66)	20–25 (66–82)
362 and above	12–17 (39–56)	15–22 (49–72)

*Surge impedance is typically 50–70 Ω .

†In the case of disconnecting and grounding switches, elbows, tees, etc., their capacitances do not vary significantly from the values per foot. A conservative value for circuit breakers will result if the length which they occupy is used to calculate the capacitance.

Table B.7—Effective capacitance of circuit breakers, circuit switchers, and disconnect switches

Apparatus description	Capacitance (pF)			
	Maximum system voltage 15–72.5 kV		Maximum system voltage 72.5–800 kV	
	Open*	Closed	Open*	Closed
Outdoor, dead-tank, air, oil, vacuum, or SF ₆ circuit breakers with oil & paper bushings	150–650	300–1300	250–550	500–1300
with SF ₆ bushings	25–150	50–300	25–150	50–300
with solid resin bushings	50–200	100–400	100–500	200–1000
Outdoor, live-tank, air, oil, vacuum, or SF ₆ circuit breakers	20–50	40–100 [†]	25–150	50–250 [†]
GIS circuit breakers	NOTE 2	NOTE 2	NOTE 2	NOTE 2
GIS disconnect switches	NOTE 2	NOTE 2	NOTE 2	NOTE 2
Outdoor SF ₆ circuit switchers	20–40	40–100 [†]	25–100	50–200 [†]
Outdoor SF ₆ circuit switchers with integral disconnect blade	25–80	60–120	30–200	80–250
Outdoor disconnect switches	20–60	30–100	30–130	60–200
NOTES: 1 — The higher values of capacitance are associated with the higher voltages. 2 — For GIS systems, the capacitance of disconnecting switches and circuit breakers does not vary greatly from the values per foot for the bus.				

*Voltage-grading capacitances or resistances may be present across the open gap of circuit breakers. Consult the manufacturer for specific values.

[†]Capacitance is based on one interrupter per pole. The closed capacitance is in proportion to the number of interrupters per pole.

Table B.8—Effective capacitance of miscellaneous equipment

Description	Capacitance (pF)
Outdoor support insulators	8–12* maximum
Outdoor lightning arresters	80–120
Outdoor current-limiting reactors	150–250

*The effective capacitance of support insulators is overshadowed by the connected apparatus' effective capacitance and it can be neglected.

Table B.9—Effective capacitance of transformers for three-phase ungrounded faults, first pole-to-open

Transformer size (MVA)	Capacitance (pF)	
	Maximum system voltage 15 to 121 kV	Maximum system voltage 121 to 550 kV
1 to 10	900 to 10 000	—
10 to 100	2000 to 12 000	2000 to 6500
100 to 1000	—	3500 to 16 000

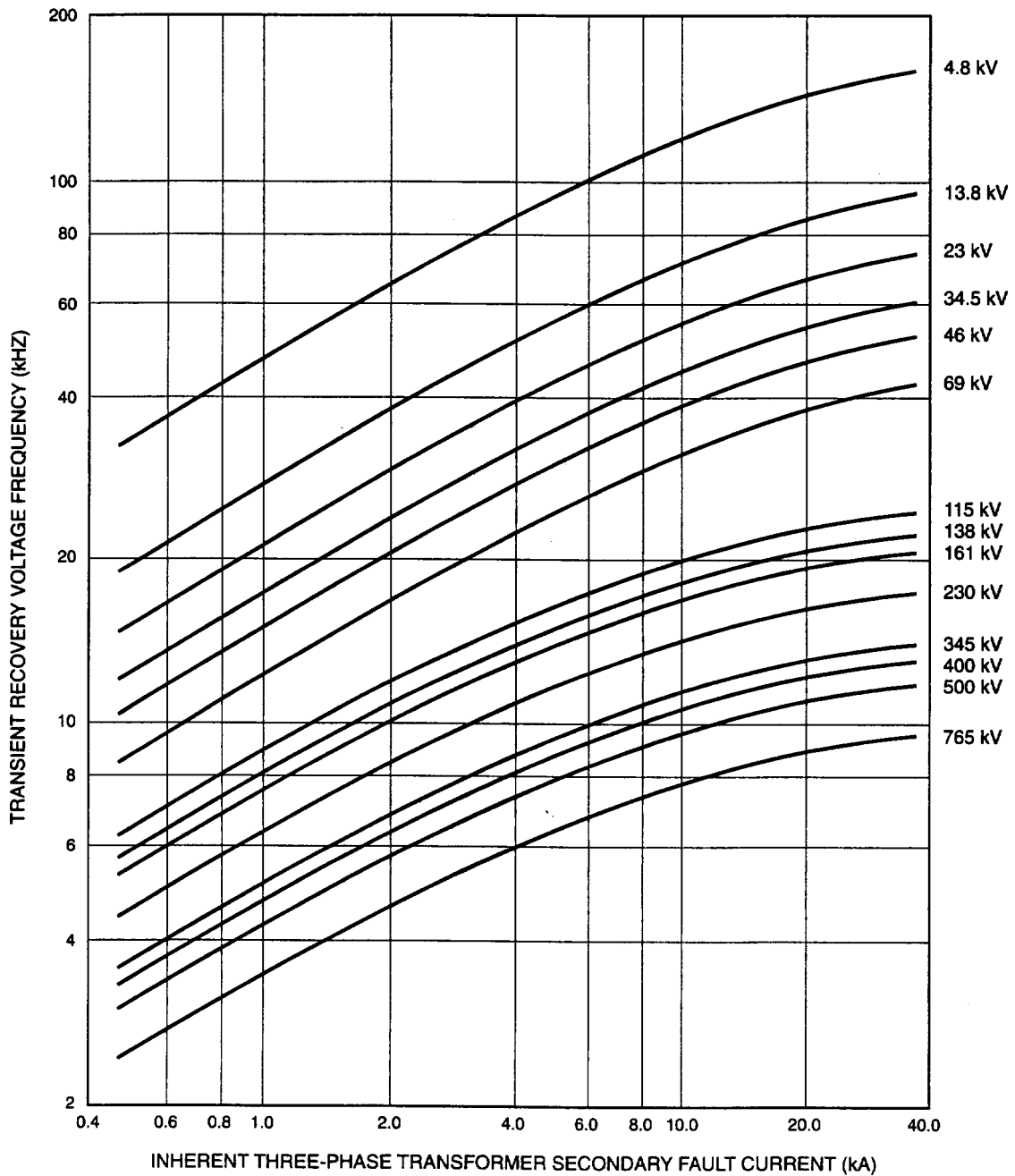

Figure B.1—Three-phase power transformer TRV frequencies across the first pole to clear for three-phase secondary faults—90th percentile curve

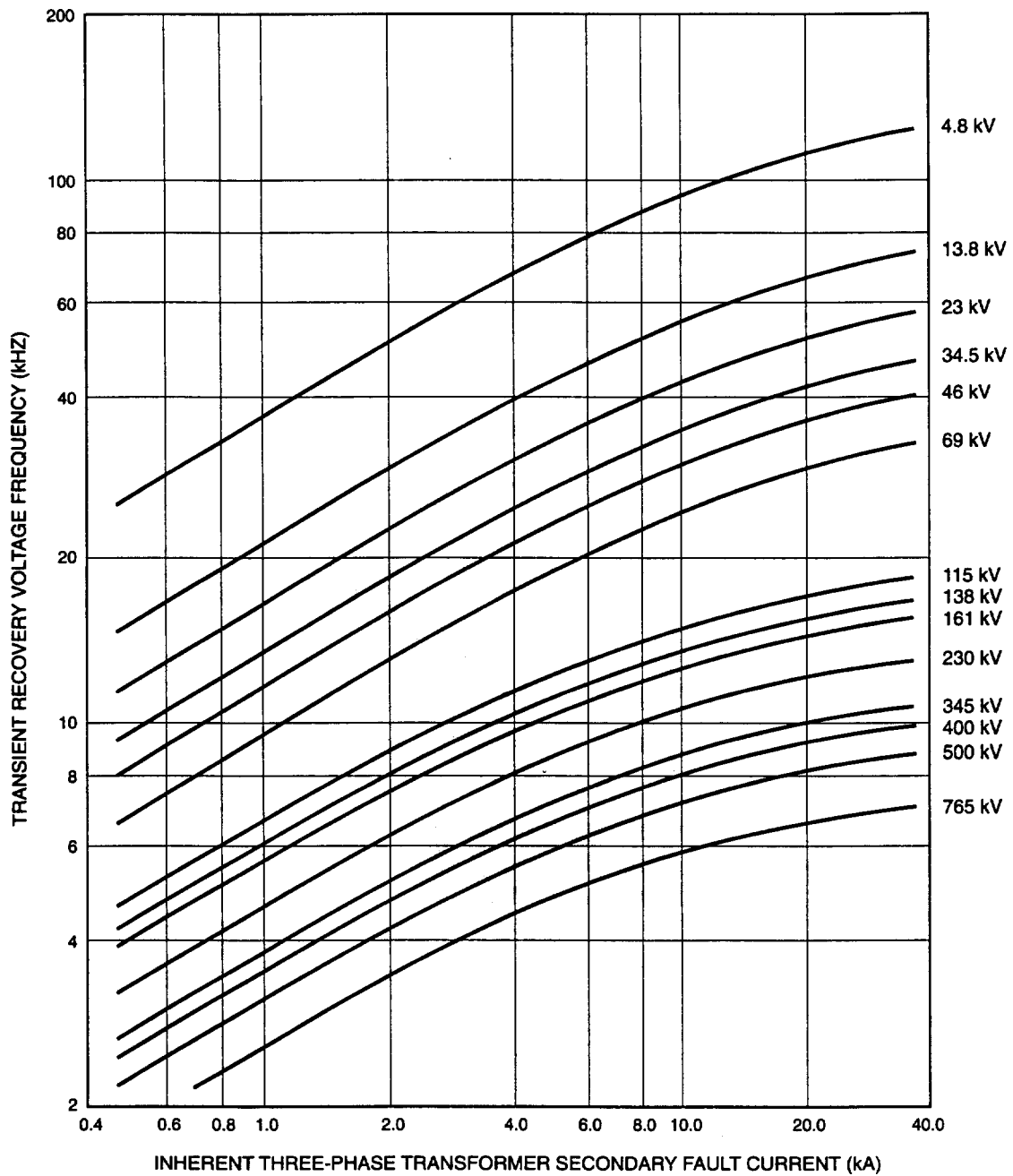

Figure B.2—Three-phase power transformer TRV frequencies across the first pole to clear for three-phase secondary faults—Median curves

Annex C Bibliography

(Informative)

- [B1] Bewley, L. V., *Traveling Waves on Transmission Systems*, (second ed.) New York: John Wiley, 1951.
- [B2] *Circuit Interruption — Theory & Techniques*, New York: Marcel Dekker, Inc., Chapter 3, 1984.
- [B3] Colclaser, R. G., Jr., Beehler, J. E., and Garrity, T. F., “A Field Study of Bus-Fault Transient Recovery Voltages,” *IEEE Transactions on Power Apparatus and Systems*, vol. PAS-95, pp. 1769–1776, Nov./Dec. 1976.
- [B4] Colclaser, R. G., Jr., Berkebile, L. E., and Buettner, D. E., “The Effect of Capacitors on the Short-Line Fault Component of Transient Recovery Voltage,” *IEEE Transactions on Power Apparatus and Systems*, vol. PAS-90, no. 2, pp. 660–669, Mar./Apr. 1971.
- [B5] Colclaser, R. G., Jr., and Buettner, D. E., “The Traveling-Wave Approach to Transient Recovery Voltage,” *IEEE Transactions on Power Apparatus and Systems*, vol. PAS-88, no. 7, pp. 1028–1035, July 1969.
- [B6] *Electrical Transmission and Distribution Reference Book*. (Fourth Edition.) East Pittsburgh, Pennsylvania: Westinghouse Electric Corp., 1950.
- [B7] Greenwood, A., *Electrical Transients in Power Systems*, New York: Wiley, 1971.
- [B8] Harner, R. H., and Rodriguez, J., “Transient Recovery Voltages Associated with Power-System, Three-Phase Transformer Secondary Faults,” *IEEE Transactions*, vol. PAS-91, pp. 1887–1896, Sept./Oct. 1972.
- [B9] Hedman, D. E., and Lambert, S. R., “Power Circuit Breaker Transient Recovery Voltages,” *IEEE Transactions on Power Apparatus and Systems*, vol. PAS-95, pp. 197–207, Jan./Feb. 1976.
- [B10] Heinmiller, W. G., Katterhenry, R. W., Lambert, S. R., and Stringer, T. R., “Transient Recovery Voltage Failure of Two 15 kV Oilless Circuit Breakers,” *IEEE Transactions*, vol. PAS-102, pp. 2578–2584, Aug. 1983.
- [B11] Naef, O., Zimmerman, C. P., and Beehler, J. E., “Proposed Transient Recovery Voltage Ratings for Power Circuit Breakers,” *IEEE Transactions on Power Apparatus and Systems*, vol. PAS-84, no. 7, pp. 580–608, July 1965.⁵
- [B12] Petitpierre, R., and Watschingen, H., “Transient Recovery Voltage Conditions to be Expected When Interrupting Short Circuit Currents Limited by Transformers,” *CIGRE* 13-07, 1970.
- [B13] *Transient Recovery Voltages on Power Systems (as Related to Circuit Breaker Performance)*. New York: Association of Edison Illuminating Companies, 1963.⁶

⁵See footnote 6.

⁶The symbols used in this reference do not correspond to the references of IEEE Std C37.100-1992.